

SCU5: Controller

Product and User Manual

Copyright Information

All of the information herein is the exclusive proprietary property of Roll-2-Roll Technologies LLC, and is disclosed with the understanding that it will be retained in confidence and will neither be duplicated nor copied in whole or in part nor be used for any purpose other than for which it is disclosed.

Information in this document is believed to be reliable and accurate. However no responsibility is assumed as a result of its use nor for any inaccuracies, infringement of patent or other rights of third parties resulting from its use.

The information in this document is subject to change without any notice.

CONTENTS

INTRODUCTION	5
Web Guiding Application	5
Web Position Sensor	6
Web Guide Controller	6
Guide Mechanism	6
Measurement and Sensing Application	6
Sensor and Web Guide Controller Specification	6
Controller Options	7
Physical Dimensions of SCU5	8
Power Input	9
Switchcraft DC Connector	9
Industrial DIN Rail Power Supply	9
Grounding	9
Sensor Interface	9
Motor Communication	10
Analog Output	10
Industrial Ethernet Interface	11
Opto-Isolated Output	11
SAFETY INSTRUCTIONS	12
Instructions for Use	12
Proper Use	12
Improper Use	12
Static Discharges and Grounding	12
OPERATION AND OPERATOR INTERFACE	13
Main Operator Interface Screen	13
Automatic/Manual Operation	13
Servo-Centering Operation	14
Jog-left/Jog-right Operation	15
Guide Point Adjustment	16
Fine Guide Point Adjustment	16
Gross Guide Point Adjustment	17
Reset Guide Point	18
Edge Position Indicators	18
Web Detected Indicator	20
Sensor Position Indicator	20
Find Sensor Button	20
Heartbeat Indicator	21

Advanced Settings	21
Password Screen	21
Operator Screen	21
Speed	21
Enable or Disable Sensor	22
Sensing Mode Selection	22
Contrast Feature Selection Screen	23
Live Preview	24
Contrast Mode Selection	24
Feature Selection	25
Teaching	25
Auto Brightness Control	25
Brightness Gauge	25
Contrast Gauge	25
Sensor Selection	26
Contrast Feature Selection Modes	26
Right edge of a contrast	26
Edge created by two contrasts	27
Contrast of a line	27
Left Edge of a contrast	28
Actuator Setting	29
Stroke	29
Pitch	30
Motor Polarity	30
Servo Center Polarity	30
Ethernet	30
Analog Output Setting	31
Output range selection	31
Analog mode	31
Analog setup	31
Remote Control and Monitoring	32
Output registers	32
Sensor status and fault registers	32
Sensor position output register	34
Quality factor registers	34
Web guide status and fault registers	35
Guide point percentage	36
Diagnostic index	36
Motor speed percentage	36
Controller Input Registers	36
Sensor command register	37

Web guide command register	37
Guide point offset register	39
Motor speed register	40
Communication Module	40
IP Address	40
Finding the IP Address	40
Setting a static IP address for the controller	41
Adding an EtherNet/IP module in Rockwell/AB Ecosystem	43
Configuring the module parameters	44
Configuring communication options	44
Importing Add-On-Instruction	46
Using SCU5 C(E) Add-On Instruction	48
Sensor variables	49
COMMISSIONING	51
Sensing and Measurement Application	51
Web Guiding Application	51
Edge Guiding	51
Center Guiding Application	52
Standard Operating Procedure	52
General Maintenance	52
TROUBLESHOOTING	53
TECHNICAL SUPPORT AND SERVICE	54
Contact information	54
Return shipping instructions	54
REVISION HISTORY	55
Document Revision	55
Hardware Revision	55
Firmware Revision	55

INTRODUCTION

This product manual provides information about installation, use and maintenance of SCU5 controller. The controller includes an operator interface that is used for both measurement and control applications within converting lines. For installation of the sensor and web guide please refer to the respective product manuals.

The controller is designed for use in indoor industrial and laboratory equipment that process materials in web form as they move through a converting or raw material manufacturing process.

The controller can be used in closed loop control applications such as web guiding applications for edge, contrast and center guiding. The controller can also be used for other standalone sensing applications such as width measurement, thread counting, mark detection, contrast position measurement, gap detection and the like.

Web Guiding Application

A web guiding system is a fully automatic mechatronic system used to accurately align/steer web materials within roll-to-roll machines. The web guide is used at critical locations where accurate alignment of web is necessary. Typical locations include at the unwind section, before process sections, such as before printing, coating, laminating, slitting, and rewind section. Accurate web guiding will improve productivity by enabling high speed transport and manufacturing.

There are three main components to a web guiding system:

1. Web position sensor
2. Web Guide Controller
3. Guide mechanism



Fig. 1: Components of a web guiding system

Web Position Sensor

The web position sensor provides the vision for the control system. The sensor captures the image of the web position (edge or a contrasting feature on the web) and sends that information to the controller for further processing.

Web Guide Controller

The controller is the brain for the control system. Based on the image captured by the sensor controller processes the image and determines the corrective action necessary to accurately align the web material. The web guide controller encloses the electronic hardware for the sensor processing, operator interface and the control algorithm for the web guide/actuator.

Guide Mechanism

The web guide mechanism is the muscle for the control system. The guide mechanism actuated by a motor physically steers the web to the required position based on the command from the controller.

Measurement and Sensing Application

The controller along with an appropriate sensor head can be used for standalone sensing applications such as edge detection, contrast position detection, width measurement, web centerline position measurement, thread counting, gap detection, etc. The sensor and the controller perform the same function however further processing is carried out by the controller to provide higher level measurement information.

Sensor and Web Guide Controller Specification

The general specifications of the SCU5 controller are listed below. Depending on the application one or more of the output options would be available.

Operator Interface	Optional color touchscreen	Output (Voltage)	± 10 V or 0 to 10 V
Languages	Language independent	Output (Current)	0 to 20 mA or 0 to 10 mA
Motor Driver	Microstepping or servo drive	Connectivity	Ethernet/IP, PROFINET
Motor	Servo or Linear hybrid stepper	Input Supply	24 V DC
Controller Frequency	50 to 200 Hz	Current	Less than 5 amps

The most basic controller is the SCU5 D which has the operator interface integrated within the controller. The controller is used for standalone measurement and sensing application. Analog output of the sensor measurement is provided so that the controller can be connected to a legacy system (legacy web guide controllers, servo valves, pneumatic valves, etc.) for closed loop control. The analog output can also be connected to a PLC for measurement monitoring application. Advanced measurement and sensing applications can utilize either the EtherNet/IP or PROFINET industrial Ethernet connectivity option.

For a web guide controller, the analog output option is replaced with an RS485 communication option to driver a web guide actuator driver manufactured by Roll-2-Roll Technologies LLC.

Controller Options

Following table shows the capabilities of the different controller option

Options	SCU5 D	SCU5 C ⁴ (X)D	SCU5 MD	SCU5 MC ⁴ (X)D
Input	24 VDC	24 VDC	24 VDC	24 VDC
Application	Sensing	Sensing	Web Guiding	Web Guiding
Analog output	YES	YES	NO	NO
Voltage output options	± 10 V ²	± 10 V ²	NONE	NONE
Current output	0 to 20 mA ³	0 to 20 mA ³	NONE	NONE
Motor Controller			YES	YES
Current Consumption	< 2.5 Amps	< 3 Amps	< 5 Amps	< 5 Amps
Controller Frequency	50 - 200 Hz	50 - 200 Hz	50 Hz	50 Hz
Industrial Ethernet		YES		YES
Web browser dashboard		YES		YES
Remote Control		YES		YES
Diagnostics/Fault Info		YES		YES
Process two sensors	YES	YES	YES	YES
GO/NO GO	YES ¹	NO	YES ¹	NO
Standalone System	YES	YES ⁵	YES	YES ⁵

¹ Two digital 24 V NPN GO/NO GO output are available upon request. This is not a standard.

² can be programmed to be ± 10 V or 0 to 10 V or ± 5 V or 0 to 5 V based on application requirement

³ can be programmed to be 0 to 20 mA or 4 to 24 mA or 0 to 10 mA based on application requirement

⁴ the industrial ethernet has two options C(E) for EtherNet/IP and C(P) for PROFINET

⁵ can be made standalone when not connected to a remote controller (PLC) or when set by remote controller (PLC)

Physical Dimensions of SCU5

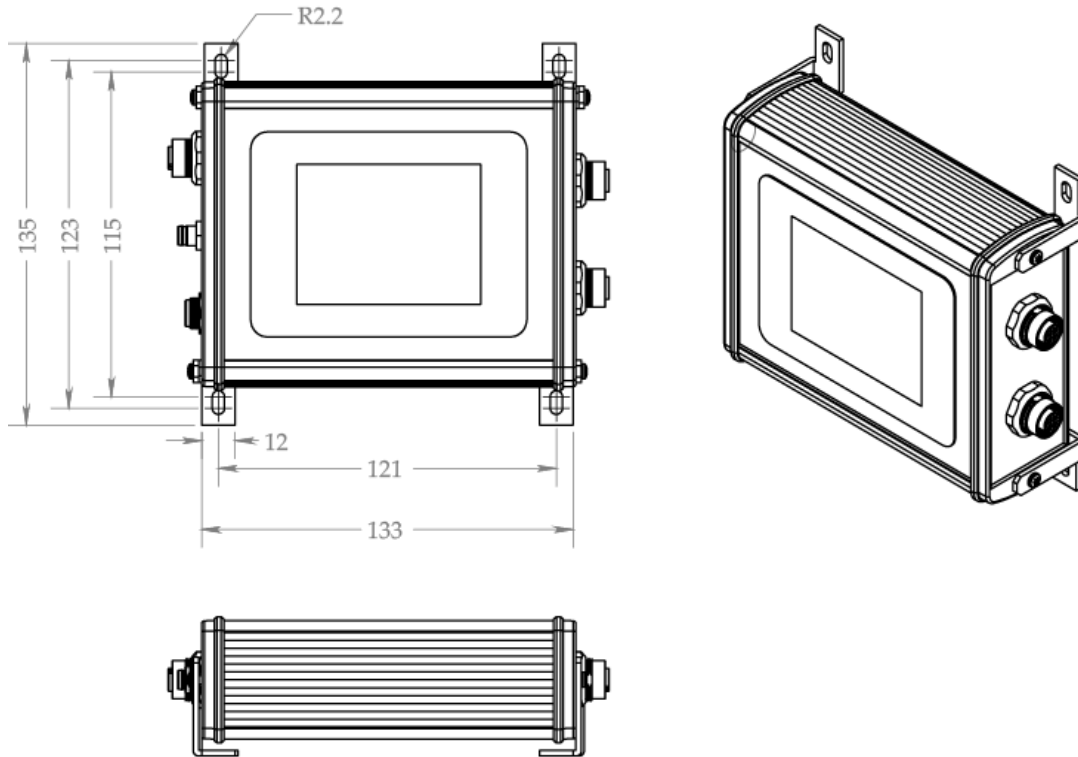

Fig. 2: SCU5 M Controller Physical Dimensions (All dimensions are in mm); Subject to change without notice.

The SCU5 M controller has the following ports available for operation.

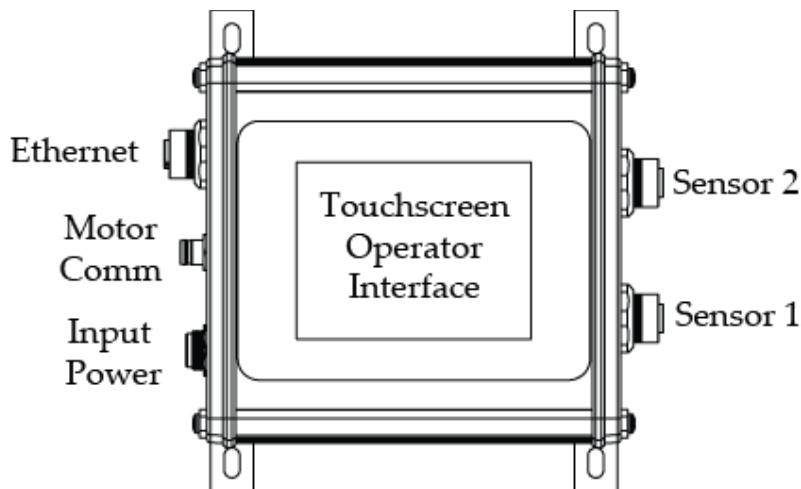

Fig. 3: SCU5 MD Connector Ports

Power Input

The SCU5 M operates under 24 VDC ($\pm 5\%$) power with a maximum current requirement of 5 Amps. The power is supplied through a Switchcraft DC power connector.

WARNING: *Supplying more than 24 VDC would damage the controller permanently.*

Switchcraft DC Connector

Sealed Switchcraft L712AS power jack port option is available on the SCU5. A mating Switchcraft 761KS12 plug connector or a pre-assembled Switchcraft CARA761KS07984 or a pre-assembled Switchcraft CA761KS07984 can be used to supply power. For the plug connector the 24 VDC power should be supplied to the tip/center pin and electronic ground on the sleeve pin. For the cable assembly the 24 VDC should be connected to the red cable and the electronic ground connected to the black cable.

Industrial DIN Rail Power Supply

Industrial DIN rail mountable power supply such as Mean Well SDR-75-24 can be used to supply 24VDC power. This is an available purchase option.

Grounding

For safety and for normal operation, the SCU5 M controller, the equipment to which the controller is installed must be properly grounded. The metal enclosure surface or the mounting screws may be used to properly ground the controller to the plant earth.

WARNING: *Please use all possible options to safely earth ground the controller. Improper grounding may result in static buildup that can potentially result in malfunction of the controller.*

Sensor Interface

Two sensor ports labeled Sensor 1 and Sensor 2 have industry standard 12-pin M12 connectors to connect the 12-pin connector on the sensor cable. Either sensor ports can be used to connect the sensor(s) and the controller will automatically recognize the connection.

WARNING: *The connectors are key and please DO NOT force the connectors. Forcing the connector may damage the pins and eventually can damage the sensor and or the controller.*

NOTE: *If two sensors are connected, the controller will automatically configure the appropriate guiding mode based on the sensor installation. If both the left and the right edge is seen by the sensor, the center guiding mode will be enabled. If both the sensors see the same edge of the web then an average of the sensor measurement will be used to guide the web.*

WARNING: *Only the sensors and cables provided by Roll-2-Roll Technologies LLC should be connected to the sensor ports. Third-party cables and sensors may damage the controller and will void the warranty. Please consult with the factory before adding any patch cords.*

Motor Communication

The SCU5 controller with “M” suffix includes a 4-pin Male M8 connector to connect the controller to a motor driver (supplied by Roll-2-Roll Technologies LLC) used for web guiding applications. A pre-wired motor communication cable with the 4-pin M8 female connectors on both ends is used to connect the controller and the motor driver. The motor communication cable carries the power and the communication signals between the SCU5 M controller and the motor driver.

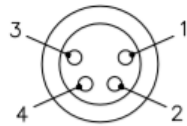

- 1 = BROWN
- 2 = WHITE
- 3 = BLUE
- 4 = BLACK

Pin	Color	Signal
1	Brown	+24 V
2	White	RS 485 B-
3	Blue	RS 485 A+
4	Black	GND

WARNING: Never connect or disconnect the motor communication cable while the SCU5 controller is powered or connected to a power supply. Always power down the SCU5 controller during the connection/disconnection of the motor communication cable.

WARNING: Only the cables provided by Roll-2-Roll Technologies LLC should be connected to the motor communication port. Third-party cables and sensors may damage the controller and will void warranty.

Analog Output

The SCU5 controller without the motor suffix will include a 3-pin Male M8 connector for analog output. The pinouts for the connector is shown below.

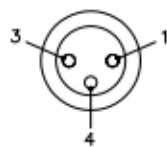

- 1 = BROWN
- 3 = BLUE
- 4 = BLACK

Pin	Color	Signal
1	Brown	Voltage
3	Blue	Current
4	Black	Ground/Common

The outputs can be pre-programmed at the factory to any of the following available output options:

Voltage	Current
0 - 5 V, 0 - 10 V, \pm 5 V, \pm 10 V	4 - 20 mA, 0 - 20 mA, 0 - 24 mA

Industrial Ethernet Interface

An optional industrial ethernet connection is available on models with suffix C(E) or C(P). A 4-pin D-coded M12 socket connect is provided for ethernet connection. Standard network cables such as Phoenix Contact NBC-MSD/ 1,0-93E/R4AC SCO - 1407360 or VS-MSD-IP20-93E/5,0 - 1403500 can be used to connect the SCU5 M to an ethernet network using RJ45 plug.

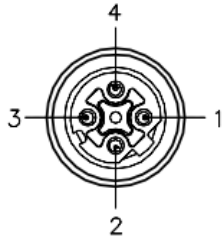

Pin	Color	Signal
1	White/Orange	+TX
2	White/Green	+RX
3	Orange	-TX
4	Green	-RX

Opto-Isolated Output

For some applications two opto-isolated output are available from the SCU5 controller. These outputs are available on a 4-pin M12 female pin connector. A standard M12 4-pin A coded male connector or a pre-wired M12 cable can be used for the connection. The pin functions for the connector are shown in the table below.

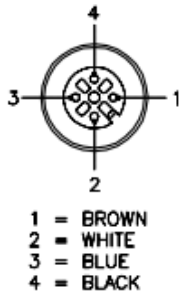

Pin	Color	Signal
1	Brown	VDD
2	White	OUT2
3	Blue	GND
4	Black	OUT1

The outputs can be used as NPN output by providing a VDD (5 - 24 VDC) and GND from a PLC and the signal through the two outputs OUT1 and OUT2. Custom programming can be done to provide a GO/NO GO type of output or a digital ON/OFF signal.

SAFETY INSTRUCTIONS

The SCU5 controller is an electronic device that operates on low voltage (24 V DC). However, it does present a few safety requirements that must be followed in order to assure safe and effective operation of the system.

Instructions for Use

The SCU5 controller must be properly transported, stored before being installed professionally. The controller should not be installed or commissioned for operation if any visible damage is observed. Only persons who have the necessary qualifications should work on the installation, commissioning, operation, and maintenance of the system.

Notes:

- Please read the product manual and properly follow its instructions
- Please read and follow the warning labels on the device
- Be aware of all national, state, and local requirements for accident prevention and environmental protection.

Proper Use

The SCU5 M controller is intended for indoor use only for use in industrial and lab equipment that process materials in web form as they move through a converting or raw material manufacturing process.

Improper Use

- Outdoor use or exposure to direct sunlight is considered improper.
- Any use outside the general specifications shall be considered improper use and voids any warranty of the equipment.
- Any replacement parts or modification necessities should be made by Roll-2-Roll Technologies LLC.

Static Discharges and Grounding

- Web, especially plastic webs, when transported over rollers can create significant static voltage potential. This static may discharge to the controller through the sensor cables. The static potential needs to be safely discharged by proper grounding of the controller.

OPERATION AND OPERATOR INTERFACE

Main Operator Interface Screen

The web guiding operation is accomplished through the main operator interface on the SCU5 controller; some models may have remote operator interface. The capacitive touchscreen on the SCU5 controller uses a language independent icon based screen that allows ease of operation. Fig. 4 shows an image of the Operator Interface screen:

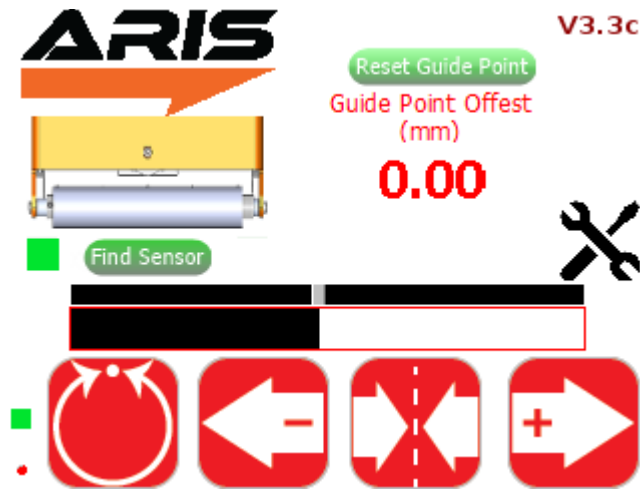

Fig.4: SCU5 Operator Interface (Manual Mode)

Never use sharp or pointed tools of any kind to operate the interface. Best practice is to have operators use their fingers to press the different icons. Care must be taken to clean the touch screen surface periodically.

Its icon based design allows for a language independent operation without the need of translation of the screen for setup and operation in different countries.

Automatic/Manual Operation



Manual



Automatic

A web guide controlled by the SCU5 controller can be put into manual or automatic operation mode by pressing this icon. The guide is in manual operation when the icon is red and is in automatic mode when the icon is green. When the guide is in manual mode and the icon is pressed, the guide will switch to automatic mode. When the guide is in automatic mode and the icon is pressed the guide will be put into manual mode.

- The guide should be placed in manual operation during initial setup of the guide, or during routine maintenance of the production line.
- The guide must be placed in automatic operation when the production line is operational.

WARNING: Changing from one mode to another can result in a change in the web guide position causing process upsets. Caution must be exercised when changing the operating mode and should be done by those who completely understand the consequence of this change.

WARNING: No personnel should be manually handling the web guide or the material around the web guide when the guide is in automatic operation. Failure to follow this warning could result in crushing of body parts at pinch points around and within the web guiding system.

WARNING: Care must be taken that only one person is working on the guide when it is in manual operation. Failure to follow this warning could result in crushing of body parts at pinch points around and within the web guiding system.

A few icons on the operator interface are enabled or disabled as the web guide is switched between manual and automatic mode based on the available options in each mode. Fig. 5 shows the operator interface while the web guiding system is in automatic mode. The advanced setup and sensing mode icons are disabled.



Fig. 5: Operator Interface (Automatic Mode)

Servo-Centering Operation



Servo-centering off



Servo-centering on

The servo-centering operation automatically centers the guide roller assembly of the guide.

- During normal operation the icon will be in red.

- Upon pressing the icon, the icon turns green and the guide automatically moves the rollers to a factory preset center position. Once centered the icon returns to red indicating that it has finished the procedure and that servo-centering is off.

The servo center feature allows the guide to be centered quickly to facilitate threading of the web during changeover.

WARNING: Servo centering operation result in a change in the web guide position causing process upset. Caution must be exercised when performing this function and should be done by those who completely understand the consequence of this change.

WARNING: Servo centering can be performed only when the web guiding system is in manual mode. Pressing the servo center icon during automatic operation will perform a different function.

WARNING: This is an automatic procedure of the web guiding system. No personnel should be performing manual work on or around the guide during the servo-centering procedure. Failure to follow this warning could result in crushing of body parts at pinch points around and within the web guiding system.

Jog-left/Jog-right Operation



Jog-left OFF



Jog-right OFF



Jog-left ON



Jog-right ON

The Jog-left/Jog-right icons allow the operator to manually move the guide roller assembly to the left or to the right as needed. These operations can be performed only when the web guide is in manual operating mode.

- The Jog-left/Jog-right operation icon indicates the operation is off when the icon is red.
- When the operator turns the Jog-left or Jog-right ON by pressing the icon, the guide will start moving to the left or right position. The respective icon will turn green during the Jog operation and will turn back to red when the operation is stopped.

The Jog operation can be stopped at any time by releasing respective icon any time during the jog. If the guide reaches the extreme position, the jog operation will stop automatically. This operation can only be performed when the guide is in manual setting.

WARNING: Jog-Left and Jog-Right operations result in a change in the web guide position causing process upset. Caution must be exercised when performing these function and should be done by those who completely understand the consequence of this change.

WARNING: Jog-Left and Jog-Right operation can be performed only when the web guiding system is in manual mode. Pressing the icons during automatic operation will perform a different function.

WARNING: This is a manual procedure of the web guiding system. No personnel should be performing work on or around the guide during the jog procedure. Failure to follow this warning could result in crushing of body parts at pinch points around and within the web guiding system.

Guide Point Adjustment

The guide point of the web guiding system (reference or the desired location of the web with respect to the sensor) is set to 50% of the sensing window of the sensor when shipped from the factory. In this setting the web will be guided to a position exactly in the middle of the sensing window. The guide point can be adjusted to a different location within the sensor range. This setting is absolute irrespective of the sensor position. The current guide point setting is indicated by the guide point indicator as shown in Fig. 6.

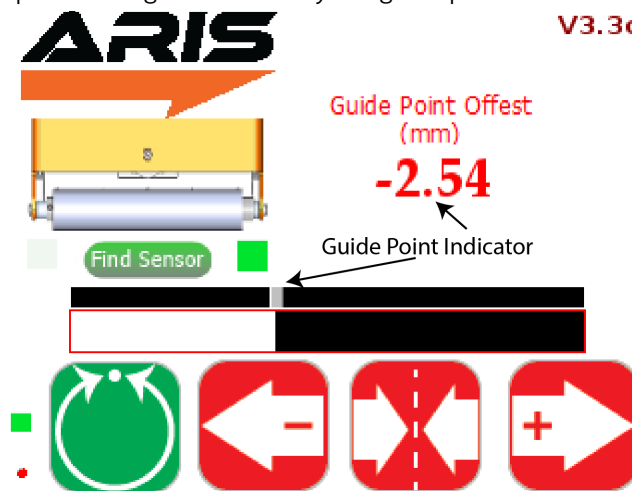

Fig. 6: Guide Point Indicator

The visual guide point indicator is a track bar that provides an easy and quick visual indication of the web edge position with respect to the current guide point. Under normal conditions, the web position should align with the guide point while the web guide is in automatic control mode. A numerical guide point indicator displays the numerical value of the guide point offset on the screen.

The guide point can be adjusted in two ways: fine guide point adjustment for small incremental adjustments and gross guide point adjustment for large step change to the guide point.

Fine Guide Point Adjustment

Fine adjustment to the guide point can only be made when the web guide is in automatic mode. These adjustments enable small incremental changes to the guide through the operator interface to enable operators to move the desired guiding position of the web. The fine adjustment to the guide point can be made by pressing the left (-) or right (+) arrow icons on the operator interface while the web guiding system is in automatic mode. Every single touch of the left or right icon will respectively decrease or increase the guide point by 0.256 mm. This change is immediately displayed by the visual guide point indicator and the

numerical guide point indicator. Pressing the middle icon (servo-centering icon) will reset the guide point to 50% or 0 mm guide point offset.

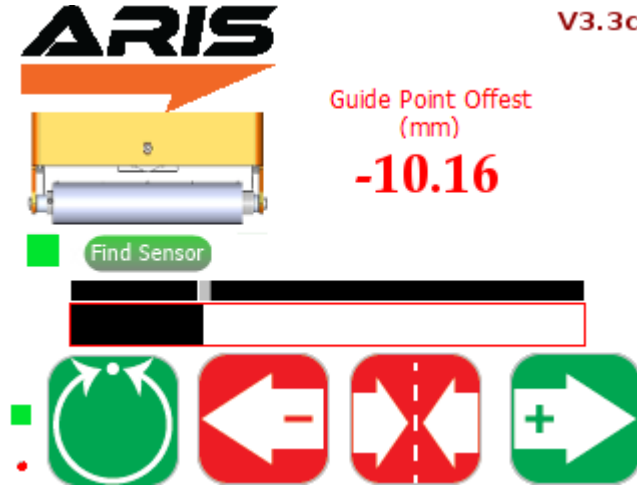

Fig. 7: Fine guide point adjustment

Gross Guide Point Adjustment

The gross guide point adjustment is intended for making a large step change in the guide point, often after a product changeover especially with a web width change. This adjustment can be made by directly sliding the visual guide point indicator track bar to the desired location; the track bar can be moved only when the web guide is in manual mode.



Fig. 8: Gross guide point adjustment

The change in the guide point needs to be confirmed by pressing the “Accept” button that appears whenever the track bar is moved. The confirmation is intended to prevent any accidental changes to the guide point. If the guide point change is not accepted within 10 seconds the change will be disregarded and the previously accepted guide point will be restored.

NOTE: The pressing of the Left (-) or Right (+) during fine guide point adjustment will momentarily change the icon to green as shown in Fig. 14. With the release of the button the icon changes the color back to red.

WARNING: The guide point adjustment operation result in a change in the web guide position causing process upset. Caution must be exercised when performing this function and should be done by those who completely understand the consequence of this change.

WARNING: Fine guide point adjustment can be performed only when the web guiding system is in automatic mode. Pressing the Left (-) or Right (+) icons during manual operation will perform the jog operations.

WARNING: Guide point adjustment should be made only if it is necessary and should be carried out by personnel with good knowledge about the consequences of the change. The performance of the guiding system may deteriorate if the guide point is too far away from the desired 50% setting. Some of the changes might have no effect if the web guide is in an extreme position.

Reset Guide Point

The reset guide point is intended to quickly change the guide point to the current web position. The feature is used in applications with frequent web width changes. Instead of manually moving the guide point using the gross or fine guide point adjustment, the guide point can be reset to the current edge position with the press of a button. When in manual mode, pressing the reset guide point button will automatically set the new guide point to the current sensor location as shown in Fig. 9.



Fig. 9: Guide point reset

The change in the guide point needs to be confirmed by pressing the “Accept” button that appears whenever the reset guide point button is pressed. The confirmation is intended to prevent any accidental changes to the guide point. If the guide point change is not accepted within 10 seconds the change will be disregarded and the previously accepted guide point will be restored.

Edge Position Indicators

Horizontal bar graph indicators (see Fig. 10) are available on the operator interface to indicate the position of the web as seen by the sensor. Both the edge position as well as the contrast position are indicated.

Depending on the position and orientation of the sensor the bar graphs may move:

- from left to right for a sensor located on the right side of the web edge

- from right to left for a sensor that is located on the left side of the web edge.
- When two sensors (one left and one right) are connected or if a wide sensor is connected the edge position indicator may indicate both the left and the right edge of the web. The green bar in the middle indicates the centerline position of the web (see Fig. 11).

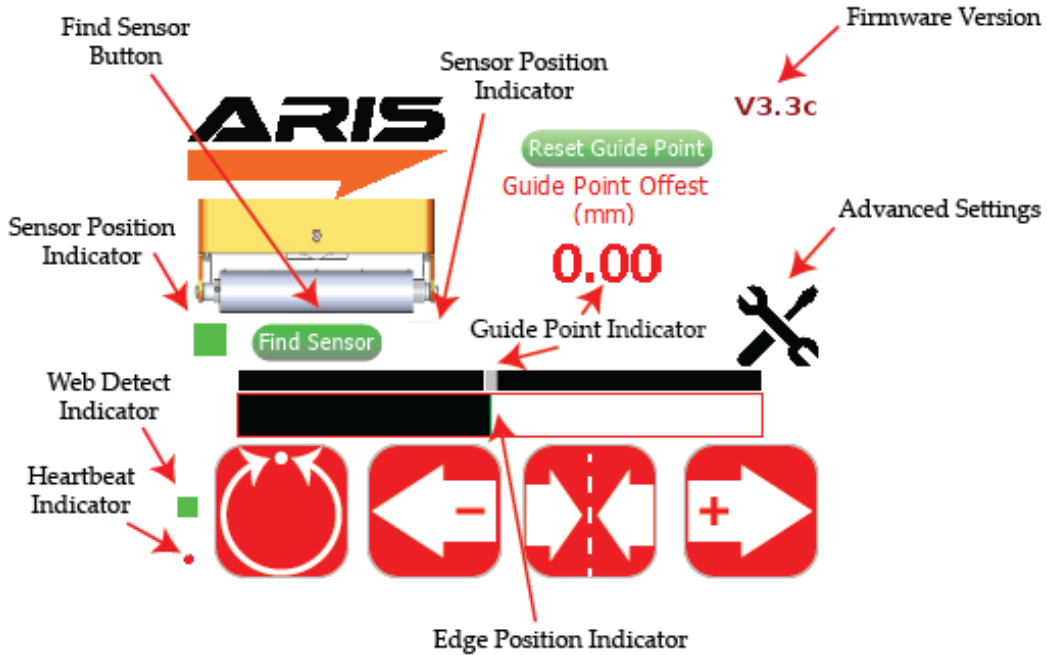

Fig. 10: SCU5 Operator Interface with annotations

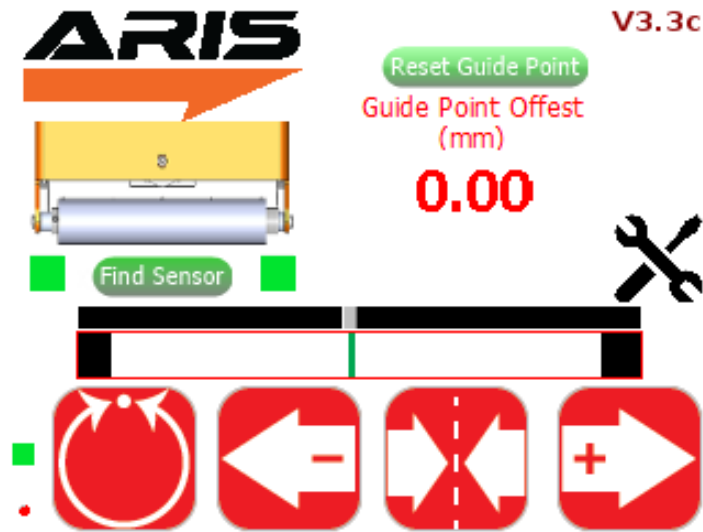

Fig. 11: SCU5 Operator Interface Showing a center sensor

Web Detected Indicator

A small square indicator on the bottom left part of the screen (see Fig. 10) indicates the presence and absence of the web as seen by the sensor.

- Whenever the sensor sees a web or a web edge, the indicator turns green.
- When the web is outside the sensing window the green indication goes off.

This web detect indicator can be used for troubleshooting purposes. If this indicator turns off intermittently while a web is in front of the sensor it may indicate that the sensor is finding it difficult to accurately sense the web. This indicates a low contrast condition for the sensor. Such a condition may occur for optical grade clear webs with low scattering in the infrared spectrum.

Sensor Position Indicator

The position of the sensor is indicated by two square indicators on the display (see Fig. 10) that are located downstream of the web guide picture.

- The indicator turns green to display the position and orientation of the sensor with respect to the guide and the web edge.
- If no sensor is attached to the web guiding system then both the indicators will turn gray.
- If two sensors (one right and one left) are attached to the web guiding system or if a wide sensor with center guiding option is used, both indicators will turn green (see Fig. 11).
- It is important to ensure that the sensor position indicator accurately indicates the actual position of the sensor with respect to the guide.
- The operator can find the correct position of the sensor by pressing the find sensor button that automatically detects the position of the sensor.

Find Sensor Button

The Find Sensor Button (see Fig. 10) can be used to automatically detect the position and orientation of the sensor with respect to the web guide and the web edge. Once the button is pressed the button will change state (as shown in Fig. 12) until the web edge is found.

- This button should be used whenever the sensor position is changed or when the edge orientation is changed.
- When the edge orientation changes, the bar graph will also change orientation.
- Find sensor button is activated only when the web guiding system is in manual mode.



Fig. 12: Find sensor operation

Heartbeat Indicator

A round indicator at the bottom left of the operator interface (see Fig. 10) indicates the heartbeat or the communication between the electronic controller board and the operator interface.

- This indicator is used for troubleshooting purpose.
- During normal operation this indicator will toggle between red and green at about 1 Hz.

Advanced Settings

The SCU5 controller provides advanced settings for contrast applications as well as for setting some parameters for the controller. The advanced settings screen will allow power users and maintenance technicians to adjust parameters to suit their web guiding needs during installation.

Password Screen

To prevent any unintended changes to the settings, password protection is enabled for power user access. Three sets of passwords are available. One is for the operator and the other two for advanced controller options used during commissioning. The passwords can be obtained by contacting the factory.

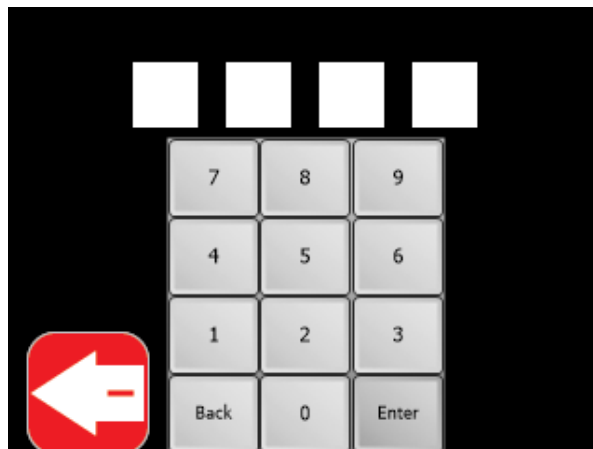

Fig. 13: Password screen for advanced settings

Operator Screen

Once the password is authenticated a settings icon will appear (as in Fig. 14). Pressing on the icon would take the user to another operator screen where the user can change the actuation speed, enable or disable sensor(s) and change the sensor mode from edge detection to contrast detection (see Fig. 15).

Speed

The actuator speed can be increased or decreased using the slider. The value set indicates the percentage of the maximum and minimum speed setting for the actuator.

WARNING: When the speed is set to 0% the web guide will not respond in the automatic mode.

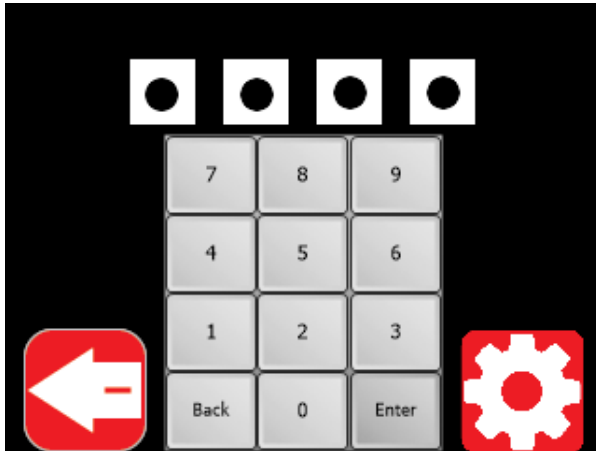

Fig. 14: Operator settings icon

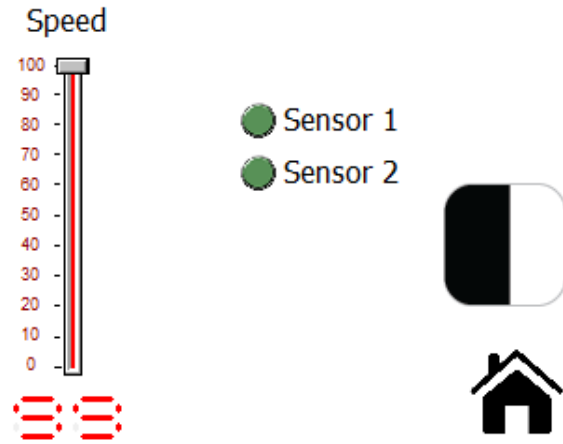

Fig. 15: Operator setting screen

Enable or Disable Sensor

One or more sensors can be enabled by pressing the dark green circle next to the sensor label. Irrespective of the physical connection in the SCU5 controller, the operation of the respective sensor is controlled by this digital switch. The analog output and the motor control output depends on this sensor selection. Fig. 16 shows a scenario where both sensors are enabled, this is the default factory setting.

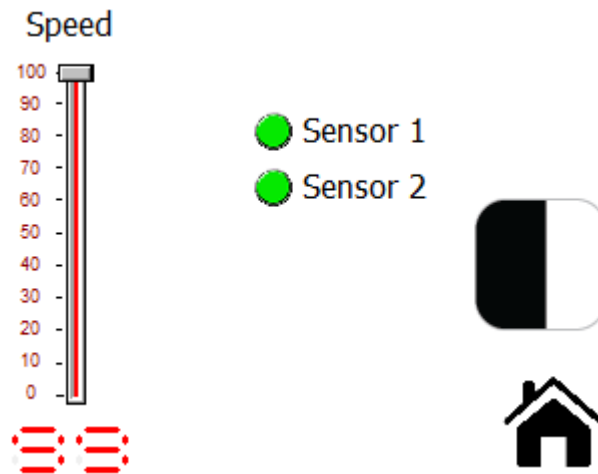

Fig. 16: Sensor enable option

WARNING: When the speed is set to 0% the web guide will not respond in the automatic mode.

Sensing Mode Selection

The operator can change the sensor mode from edge sensing to contrast sensing by toggling the sensing mode selection icon. When the icon is black and white the controller operates in edge sensing mode. When the icon is black, green and white then the controller operates in contrast mode (see Fig. 17). A tools icon will appear whenever the sensor mode is selected to contrast sensing mode. Pressing the icon will take the user to the contrast teaching mode.

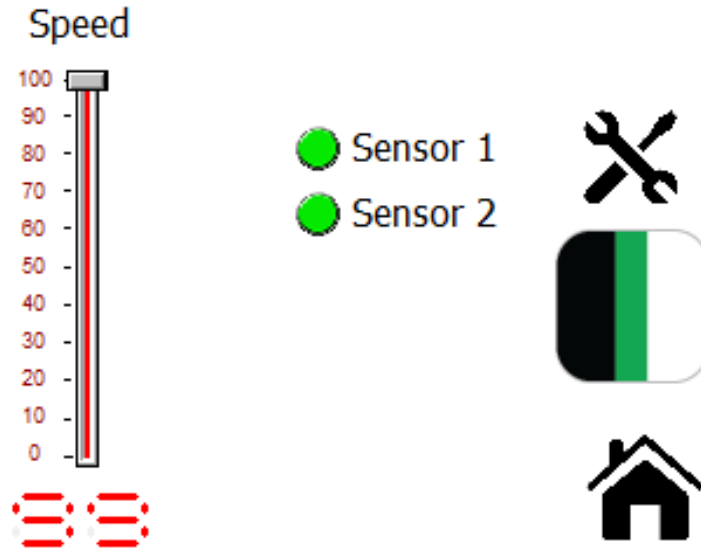

Fig. 17: Contrast sensing mode enabled

NOTE: Contrast mode should only be used when a contrasting feature on the web needs to be measured or guided. Please refer to sensor documentation for the correct type of sensor that can be used for contrast mode.

Contrast Feature Selection Screen

The contrast feature selection screen enables the operator to teach the controller to pick and follow the desired feature on the web. The various options available for the user to select are shown in Fig. 19.

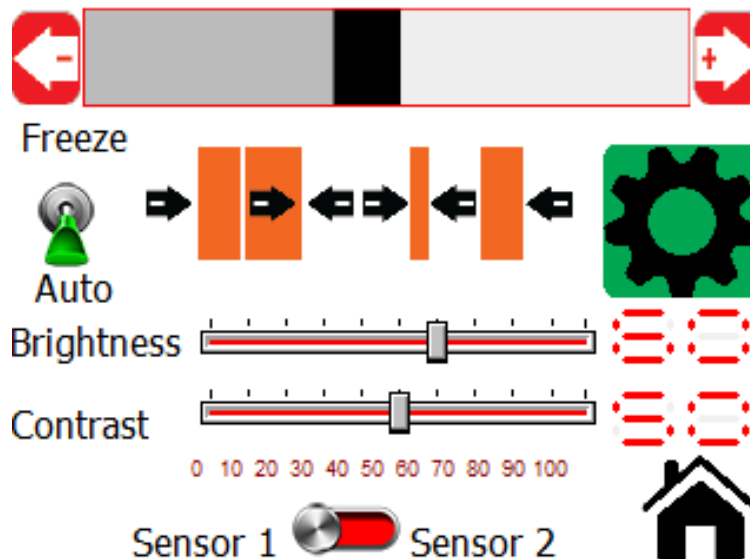

Fig. 18: Contrast feature selection screen

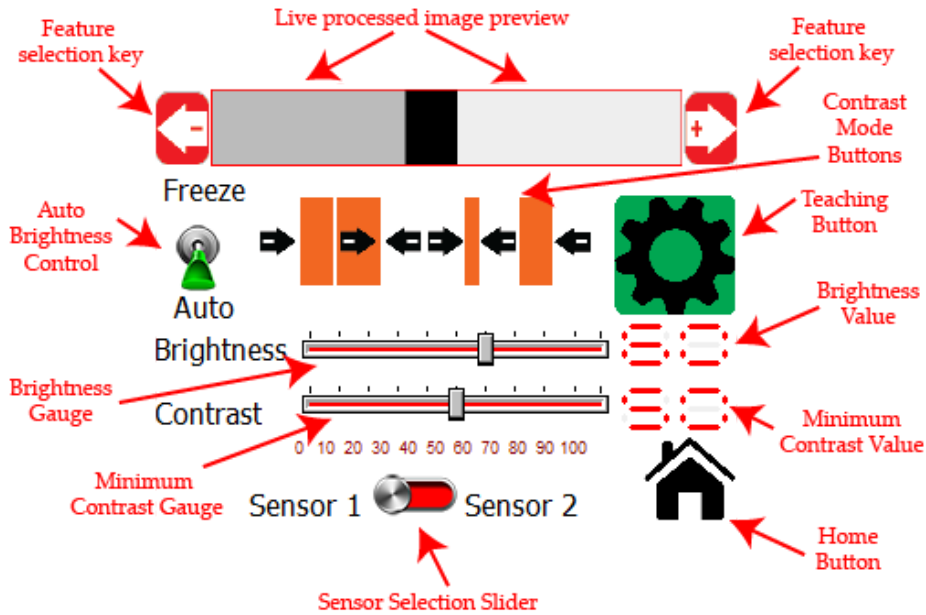

Fig. 19: Annotated contrast feature selection screen

Live Preview

The rectangular box on the top shows a processed grayscale live preview of the image seen by the sensor. The different shades of contrasts seen by the sensor appear as rectangles in the image preview window. When a region of the web scatters low amount of light back to the sensor, the region appears black or dark; while the region that scatters more light appears white or light.

Contrast Mode Selection

Four different contrast modes are available for the user. These include right edge of a contrast, edge created by two contrasts, the position of a line with contrast, and left edge of a contrast. When a certain mode is selected the region of interest is highlighted in the icon (as shown below) as well as on the live preview.

Delected				
Selected				

Feature Selection

The left and right arrow keys can be used to scroll through the image preview to select the appropriate contrasting feature of interest for the user. Depending on the mode chosen the arrow keys will move the edge or the line to the left or to the right.

NOTE: The feature selection key can be used only when the controller is in teaching mode.

Teaching

When the controller is in teaching mode, the gear icon will appear green. The user can press the left and right feature selection keys to navigate to the feature of interest. To save the teaching, so that the controller can follow the feature of interest, the gear icon can be pressed again. Successful teaching and saving of the feature of interest will turn the gear icon to red and all the contrast mode icons will disappear, except for the selected contrast mode.

NOTE: If an appropriate feature is not selected then the feature selection will not be saved. For example, the leftmost region in Fig. 19 cannot be selected using the line mode. The line mode expects two edges within the sensor viewing area.

WARNING : When teaching is saved, the controller will look for the first appearance of the feature of interest from left to right. If there are two features with the same conditions within the sensor view the left most feature would be selected. It is highly recommended to teach on a unique feature in the sensor view to increase the robustness of the measurement.

Auto Brightness Control

The controller has an automatic brightness control algorithm that adjusts the brightness of the LEDs in the sensor based on the image captured. The switch can be used to turn off the auto brightness control and allow the user to take control of the sensor LEDs brightness manually.

NOTE: This feature is intended for advanced users and by default the brightness control should be allowed to change automatically.

Brightness Gauge

When the brightness control is set to be in manual mode, the gauge can be used to manually set the brightness by sliding the gauge left to right. The brightness can be changed from 0 to 100%.

NOTE: This feature is intended for advanced users and by default the brightness control should be allowed to change automatically.

Contrast Gauge

The minimum contrast that is required to perceive an edge can be set using this contrast gauge. When the contrast value is lowered the controller becomes sensitive to small contrast changes in the image captured. Hence more and more edges with low contrast will be picked by the controller. When the contrast value is

set high, the edges with high contrast values will be seen while the low contrast edges would be disregarded.

NOTE: Set the contrast as high as possible while the feature of interest is still visible. This will increase the robustness of the sensor.

Sensor Selection

The sensor selection slider can be used to select the appropriate sensor connected to the controller during the teaching process.

WARNING: If two sensors the user can teach both the sensors. However, only one sensor can be used for web guiding purposes. The current sensor selected on this slide will be used for guiding purposes.

WARNING: If two sensors the user can teach both the sensors. However, only one sensor can be used to provide an analog output. Irrespective of the sensor selection, the analog output will always correspond to the sensor 1.

Contrast Feature Selection Modes

Right edge of a contrast

In this mode the controller will look for the right edge of a certain contrast as shown below in Fig. 20 and Fig. 21. A three sided open rectangle will highlight the contrast region of interest with the right edge of the contrast region highlighted in green. The user can press the feature selection arrows to navigate to the region of interest. When the desired region of interest is highlighted, the teaching can be saved by pressing the gear icon. Once the teaching is saved, all other contrast modes will disappear and the gear icon will turn red (as shown in Fig. 21).

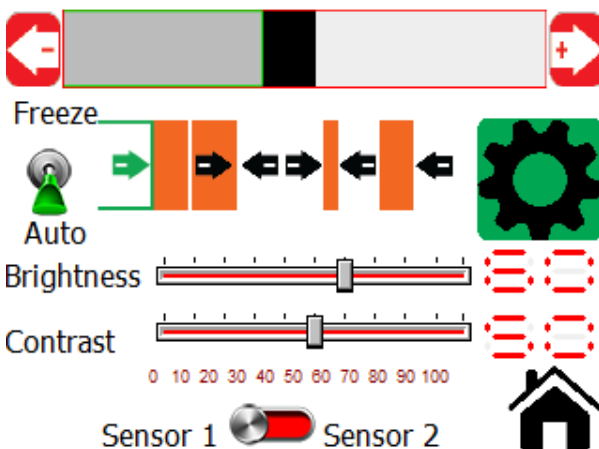

Fig. 20: Right edge of a contrast (Teaching)

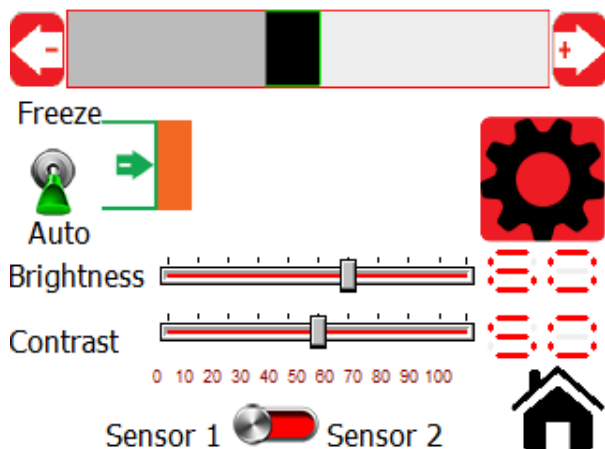

Fig. 21: Right edge of a contrast (Teaching Saved)

Edge created by two contrasts

In this mode the controller will look for an edge created by a certain contrast on the left and certain contrast on the right. Two regions will be highlighted along with the edge that is of interest (as shown in Fig. 22 and Fig. 23). The controller will look for the first appearance of the exact match of the edge with the two contrasts on either side with the appropriate order. Once the teaching is saved, all other contrast modes will disappear and the gear icon will turn red.

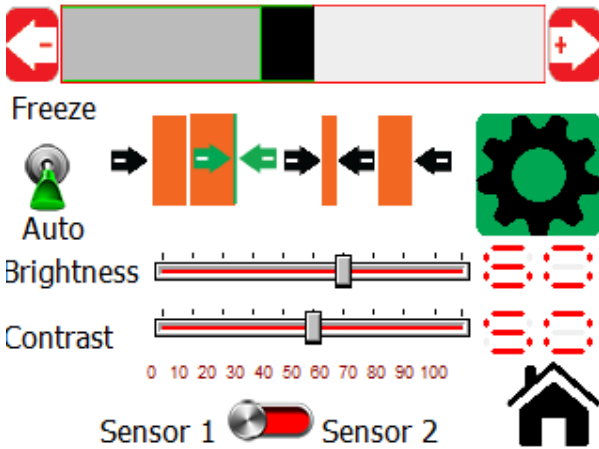

Fig. 22: Edge with two contrasts (Teaching)

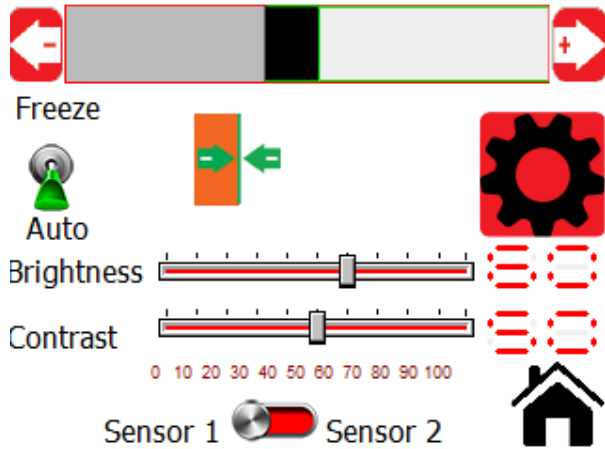

Fig. 23: Edge with two contrasts (Teaching Saved)

Contrast of a line

In this mode any region with two edges can be used for tracking purposes. The controller will look for two conditions to track the feature: (1) contrast and (2) the width of the contrast. Since two conditions need to be satisfied, this is one of the most robust contrast modes. Once the teaching is saved, all other contrast modes will disappear and the gear icon will turn red. The controller always pick the first occurrence of the contrast with a certain width while scanning from left to right once the teaching is saved.

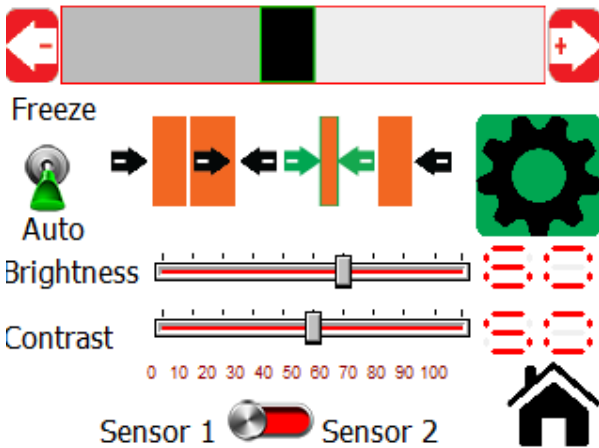

Fig. 24: Contrast of a line (Teaching)

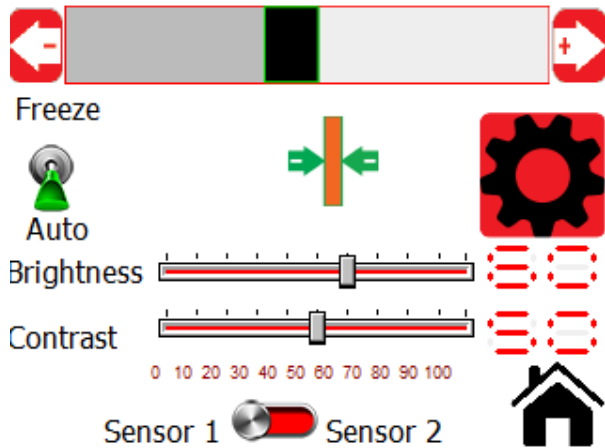

Fig. 25: Contrast of a line (Teaching Saved)

Left Edge of a contrast

Similar to the right edge of a contrast, this mode will allow the user to track the left edge of a certain contrast. In teaching mode, a rectangular region of interest and the left edge of that region will highlight the region. Once the desired region is selected the teaching can be saved by pressing the gear icon. If the saving is successful all other modes will disappear and the gear icon would turn red.

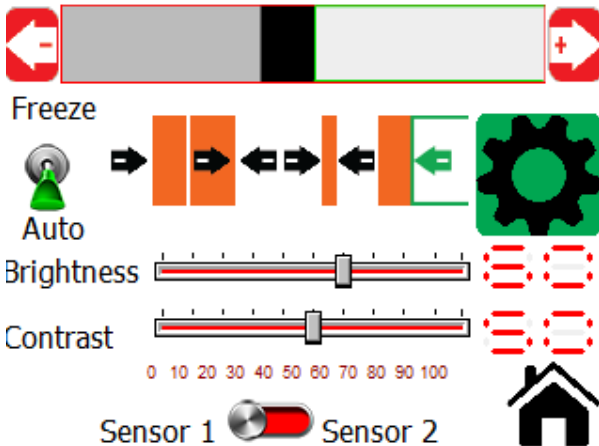

Fig. 26: Left edge of a contrast (Teaching)

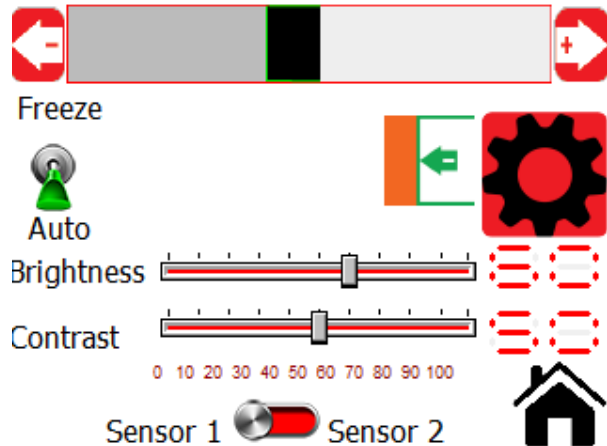

Fig. 27: Left edge of a contrast (Teaching Saved)

Once the teaching is complete and operator presses the home button the contrasting edge position will be tracked on the home screen with a green bar highlighting the live view of the contrast position.

NOTE: While teaching, the controller will not scroll through a region without a proper definition of the feature in that respective mode. For example, the user cannot pick and teach for the leftmost region on the screen while in the left edge of a contrast mode. This is because the leftmost edge cannot be outside the sensor viewing area. Similarly the controller will not pick the leftmost or rightmost region when in line mode since for a line both edges need to be visible in the sensor viewing area.

WARNING: While teaching, the controller would allow the user to pick a non-unique region of interest. However, after teaching the controller will always track the first occurrence of the non-unique region while scanning from left to right.

NOTE: No region will be highlighted if the feature of interest is not in the field of view of the sensor. This condition is called the “No Contrast” condition.

NOTE: While in automatic mode for web guiding, the web guide will automatically go to an interlock mode and will prevent the web guide to actuate whenever a no contrast condition is seen. As soon as the feature of interest reappears the web guide will actuate.

NOTE: When no contrast condition occurs, the analog output will provide the middle value of its output range. The digital output through ethernet would have a number equal to the total number of pixels in the sensor. Under normal operation, the digital contrast position output would range between zero and (number of pixels - 1).

Actuator Setting

The actuator setting screen allows the power user to set the actuator parameters such as stroke length, lead screw pitch, actuator speed, the motor polarity and the servo center polarity.

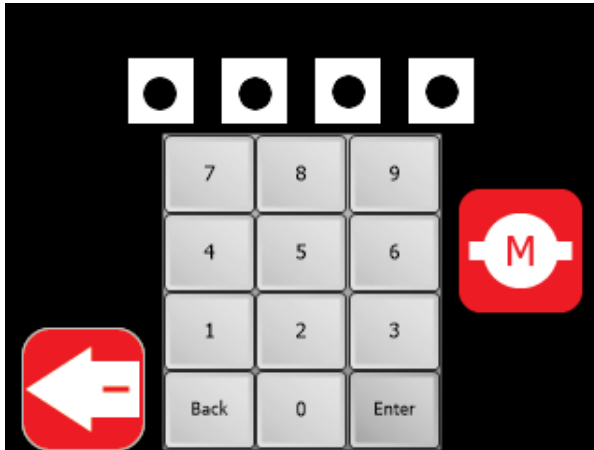

Fig. 28: Actuator/Motor settings icon

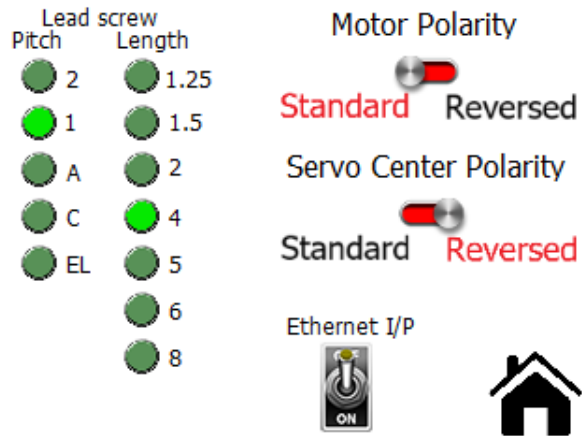

Fig. 29: Actuator settings screen

WARNING: The actuator parameters are typically preset from the factory and should only be changed with consultation with the factory. Except for speed and acceleration all other parameters need not be changed ones the web guide is commissioned for operation.

NOTE: The actuator parameters are intended to be changed by maintenance personnel with sufficient knowledge about the web guide and its performance. Most often these settings are changed during initial commissioning, after an actuator upgrade or replacement and/or with after a retrofit installation.

Stroke

The digital stroke length can be changed with the predefined selection. The units of stroke length is in inches. Pressing the green button will highlight the selected stroke with the button turning lime green.

NOTE: The actuator position is tracked digitally using software and the actuator stops actuating once the digital limits are reached. The digital limit of the actuator may not correspond to the physical limits of the web guide. These digital limits are available to prevent the actuator from hitting the mechanical limits and to avoid any possible motor burnout.

WARNING: Never set the stroke length more than the physical stroke length of the actuator. Setting a stroke length more than the physical stroke available in the actuator may cause actuator damage.

NOTE: The servo center position is used to reset the digital position count whenever the web guide is servo centered.

Pitch

The pitch setting is used to set the lead screw pitch. This setting is pre-set at the factory and should not be changed without consultation with the factory. The pitch can be changed with the predefined selection. Pressing the green button will highlight the selected pitch with the button turning lime green.

WARNING: *Changing the pitch setting would affect the digital position count of the actuator and hence the effective stroke of the actuator. Setting the pitch higher than the actual pitch would reduce the effective stroke length and vice versa.*

WARNING: *Never set the pitch to a value that is less than the actual pitch. This can result in the actuator reaching its mechanical limits and possible actuator damage.*

Motor Polarity

The motor polarity setting is used to reverse the direction of the actuator. This setting changes the behavior of the actuator both in automatic mode as well as in manual mode. Depending on the sensor installation the motor polarity needs to be reversed to make sure that the correction is in the correct direction.

WARNING: *If the motor polarity is set incorrectly the web guide will move in the opposite direction of the desired correction when in automatic mode. This is an immediate indication of the incorrect setting.*

Servo Center Polarity

The polarity of the servo center can also be changed. This may be necessary if the location of the servo center is changed or if a different type of servo center sensor is used.

WARNING: *If the servo polarity is set incorrectly the web guide will move away from the middle position when the servo center button is pressed. This might cause the actuator to hit the mechanical limits and might cause damage to the actuator.*

Ethernet

The ethernet communication can be enabled or disabled using the switch. This switch should be enabled only when the ethernet communication option is available in the controller. By default the switch will be turned OFF by default in the factory when a controller does not have an ethernet communication option. And the switch will be turned ON by default in the factory when a controller with an ethernet communication option is purchased.

WARNING: *If the ethernet switch is turned ON when no ethernet module is present, the controller may exhibit unintended behavior.*

Analog Output Setting

Output range selection

The analog output setting can be changed based on the application. An icon will appear on the password screen when the appropriate password is entered (Fig. 28). And pressing the icon will take the user to the analog output setting screen (Fig. 29). The voltage ranges and the current ranges can be set by picking the appropriate selection. The available voltage options are 0 to 5 V, 0 to 10 V, - 5 to 5 V and - 10 to 10 V. The available current options are 0 to 10 mA, 0 to 20 mA, 0 to 24 mA and 4 - 24 mA.

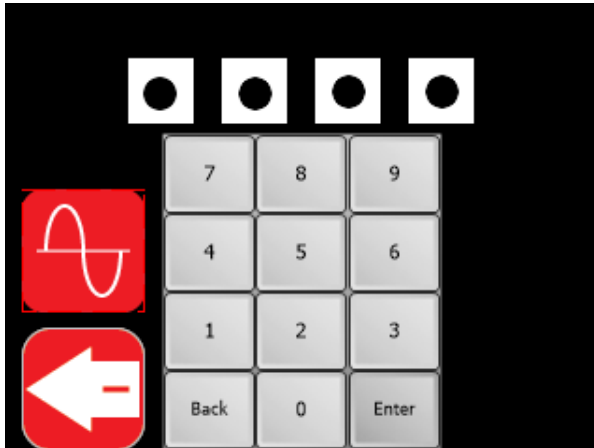

Fig. 28: Actuator/Motor settings icon

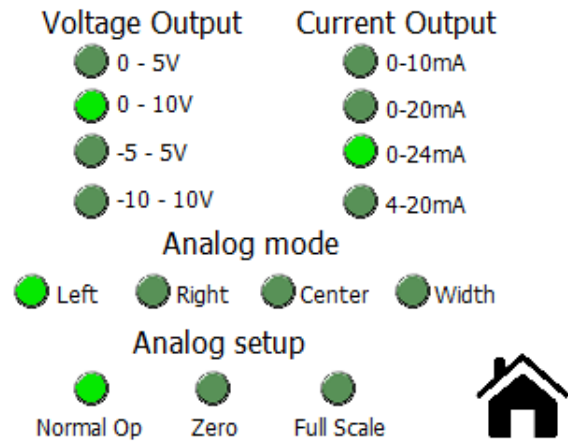

Fig. 29: Actuator settings screen

NOTE: Any combination of the voltage and current setting can be selected, except when 0 - 10 mA is selected the voltage output is automatically set to 0 - 5 V.

Analog mode

While in edge mode the controller can be programmed to provide the position of the left edge, or right edge or centerline position or the web width. The analog mode can be changed only if the sensor see both edges of the web. Selecting the appropriate analog mode button will enable the user to accomplish the functionality.

NOTE: When only one edge is seen by the sensor or when the sensor is in single edge mode, the analog mode cannot be changed. The controller will automatically select the appropriate edge and by default will provide the single edge position through the output.

Analog setup

The controller can be programmed to provide the zero scale value or full scale value by pressing the appropriate button. This functionality is useful while calibrating a legacy system. After calibration the controller can be switched back to normal operation by clicking on the Normal Op button.

Remote Control and Monitoring

A set of input and output registers are available to monitor and control the web guide controller remotely using industrial ethernet communication such as EtherNet/IP or PROFINET. The remote control and monitoring is available for advanced end users, OEMs and integrators to seamlessly integrate the web guide controller into their existing machine. For more information about these advanced features please consult the factory. It is possible to control/operate the web guide controller without an operator interface and directly using the industrial ethernet connection. The following section describes the advanced settings for the industrial communication.

Output registers

The output registers from the controller provide information about the sensor(s) and the web guide controller. The data includes status/fault information, sensor position information and sensor measurement quality information, web guide fault information, motor speed information and the current guide point information. The data from the controller is organized in the following registers:

Register #	bit 15	bit 14	bit 13	bit 12	bit 11	bit 10	bit 9	bit 8	bit 7	bit 6	bit 5	bit 4	bit 3	bit 2	bit 1	bit 0
0	Sensor 1 status/fault register															
1	Sensor 2 status/fault register															
2	Sensor 1 position output															
3	Sensor 2 position output															
4	Sensor 1 quality factor								Sensor 2 quality factor							
5	Web guide status/fault register															
6	Guide point percentage								Diagnostic index							
7	Motor speed percentage															

Sensor status and fault registers

The sensor status/fault register is organized as follows. The eight least significant bits correspond to fault information while the eight most significant bits correspond to status information.

Bit #	Value	Label	Description
0	0/1	No sensor	0: if a sensor is present 1: if no sensor is connected

1	0/1	Low contrast	0: if measurement contrast is high 1: if measurement contrast is low
2	0/1	No web	0: if web is detected by the sensor 1: if the sensor cannot detect a web
3	0/1	Wrong orientation	0: if sensor orientation is correct 1: if the sensor see an edge in the opposite orientation to which it is set up
4	NA		Reserved for future use
5	0/1	Flutter	0: if no flutter is detected 1: if the sensor detects flutter or out of plane movement in the web
6-7	NA		Reserved for future use
8	0/1	Left Sensor	0: if the sensor not set as a left sensor 1: if the sensor is set as a left sensor
9	0/1	Right Sensor	0: if the sensor not set as a right sensor 1: if the sensor is set as a right sensor
10-12	0-4	Number of pixels	The number of pixels in the sensor 0: 256 1: 768 2: 1774
13-15	0/2	Sensing mode	0: edge sensing mode 2: contrast position sensing mode

Note: If both the left sensor and the right sensor bits are set then the configuration corresponds to center sensor mode. For wide sensors (such as WPS 221) a single sensor may be used to measure the position of the two edges of the web, if the width of the web is smaller than the sensing window of the sensor.

Sensor position output register

The sensor position output register provides the absolute measurement in pixels. The output ranges from 0 to the number of pixels in the sensor, and depending on the sensor orientation the output corresponds to edge position or contrast position. In order to convert the position into a physical unit, such as millimeters or inches, the sensor resolution and the total pixel number of the sensor head are necessary. The following table provides a summary of the resolution and pixel count information for the different WPS models.

Model	Resolution	Total Pixel Count
WPS 16	0.0635 mm or 0.0025 in	256
WPS 48	0.0635 mm or 0.0025 in	768
WPS 221	0.127 mm or 0.005 in	1774

In either sensor orientation (left or right) the measured position increases as the web moves from left to right.

Note: The output when the web completely covers the sensor or when the web is completely outside the sensor window would be different based on the sensor orientation.

Sensor Orientation	Completely open	Fully covered
Left sensor orientation	Number of pixels	0
Right sensor orientation	0	Number of pixels

If no sensor is present then the value in the sensor position output register is meaningless.

With a wide sensor (such as WPS 221) center guiding with one sensor is possible if the width of the web is smaller than the sensing window of the sensor. When a single sensor acts as center sensor both the left and the right edge will be output via the industrial ethernet option. Irrespective of the sensor number the output for the left edge of the web is always available at the Sensor 1 position output register and the right edge of the web is available at the Sensor 2 position output register. *Note: If two sensors are connected and both are in center sensor mode the Sensor 1 position output and Sensor 2 position output will always correspond to the left and the right edge of the web seen by Sensor 1. Likewise for guiding purposes, the web guide will guide to the center of the web as measured by Sensor 1. The Sensor 2 output will be disregarded.*

Quality factor registers

The quality of the sensor measurement from the two sensors are provided in register 4. Higher number corresponds to good quality measurement while a low number indicates lower quality. The value of the quality factor ranges from 0 to 256. The eight most significant bits of register 4 corresponds to the 8-bits quality factor from sensor 1 while the eight least significant bits corresponds to the quality factor of sensor 2.

Web guide status and fault registers

Bit #	Value	Label	Description
0	0/1	No operator interface	0: if no operator interface is detected 1: if an operator interface is detected
1	0/1	No motor driver	0: if no motor driver is detected 1: if a motor driver is detected
2	0/1	Motor fault detected	0: if motor motor function is normal 1: if a motor fault is detected
3	0/1	Disturbance detected	0:if no disturbance is detected 1: if a disturbance is detected
4	0/1	Traction issue detected	0: if no traction issue is detected 1: if a traction issue is detected
5	0/1	Upstream misalignment	0: if no upstream misalignment is detected 1: if an upstream misalignment is detected
6	0/1	Guide extreme position	0: if the web guide is within the normal position 1: if the web guide is in an extreme position
7	0/1	High frequency disturbance detected	0: if a high frequency disturbance is detected 1: if no high frequency disturbances are detected
8	0/1	Manual/Auto	0: if the web guide is in manual mode 1: if the web guide is in automatic mode
9	0/1	Jog Left operation	0:if the web guide is not jogging left 1: if the web guide is jogging left

10	0/1	Jog Right operation	0: if the web guide is not jogging right 1: if the web guide is jogging right
11	0/1	Servo Centering operation	0: if the web guide is not servo centering 1 if the web guide is servo centering
12	0/1	Good guiding performance	0: if the guiding performance is not good 1: if the guiding performance is good
13-15	NA		Reserved for future use

Guide point percentage

The guide point for the web guide is provided in this register. The value of the guide point range between 0 and 100, representing the guide point as a percentage of the sensor range. A value of 50 indicates that the guide point is at the middle of the sensing window while a value of 25 means the guide point is at the 25% of the sensor window (left of the middle) while a value of 75 means the guide point is at 75% of the sensor window (right of the middle). The eight most significant bits of register 5 provide the guide point percentage output.

Diagnostic index

The diagnostic index output is only available with web guiding that include the KOIOS diagnostic index. The value ranges between 0 and 100. For more details please refer to the KOIOS diagnostics product manual. The eight least significant bits of register 5 provide the diagnostic index output.

Motor speed percentage

The motor positioning speed as a percentage of maximum speed is output in register 7. The value ranges between 0 and 100.

Controller Input Registers

Sensor input registers are control registers that are used to control/configure the parameters of each sensor. One 16-bit command register for each sensor is available for an external device to set the sensor parameters. The input registers are mapped as shown below:

Register #	bit 15	bit 14	bit 13	bit 12	bit 11	bit 10	bit 9	bit 8	bit 7	bit 6	bit 5	bit 4	bit 3	bit 2	bit 1	bit 0
0	Sensor 1 command register															
1	Sensor 2 command register															

2	Guide command register
3	Guide point offset register
4	Motor speed percentage register

Sensor command register

Bit #	Value	Label	Description
0-1	0/2	Sensor orientation	0: set sensor orientation to be right sensor 2: set sensor orientation to be left sensor Note: Changing this value will take effect only if bit 5 is set to 1. The auto switch mode needs to be disabled to take control of the sensor orientation through this register.
2-3	0/1		Reserved for future use
4	0/1	Sensing mode	0: set the sensing mode to be edge mode 1: set the sensing mode to be contrast mode
5	0/1	Disable auto switch off	0: Automatic switch is enabled 1: Automatic switch is disabled Note: This bit needs to be set in order to force the sensor orientation externally. If this bit is cleared to zero the sensor will maintain the previous orientation until the sensor automatically detects the sensor orientation when (1) find sensor is enabled or (2) when a new sensor is plugged into the sensor port.
6	0/1	Find sensor	0: Disable find sensor operation 1: Enable find sensor operation by resetting the orientation and allowing the sensor to detect the web orientation. Note: This bit is momentary when set to one. Every time the find sensor operation needs to be enabled the bit needs to be cleared to zero before setting it to one.
7	0/1	Disable analog output	0: Enables the analog output for the sensor 1: Disables the analog output for the sensor
8-15	0-255	Minimum contrast	Minimum contrast: Minimum contrast required to accept an edge in contrast mode Default value is 50.

Web guide command register

Bit #	Value	Label	Description
0-7	NA		Reserved for future use

8	0/1	Remote control	<p>0: if cleared to zero, the local operator interface have control over the web guide</p> <p>1: if set to one, the remote ethernet controller has control over the web guide. The interface icons to control the web guide on the local operator interface will be disabled. Information for monitoring purposes will be displayed on the screen.</p>
9	0/1	Manual/Auto mode	<p>0: if cleared to zero, the web guide will be placed in the manual mode</p> <p>1: if set to one, the web guide will be placed in the automatic mode</p>
10	0/1	Jog Left or decrease guidepoint	<p>This bit performs two functions based on bit 9.</p> <p>If bit 9 is cleared:</p> <ul style="list-style-type: none"> 0: Stop Jog Left operation 1: Start Jog Left operation <p>Note that this register is a write only register and will not change state if the web guide reaches the extreme position.</p> <p>If bit 9 is set:</p> <ul style="list-style-type: none"> 0: will clear the register and has no effect 1: will decrease the guide point by 0.254 mm or 1/100th of an inch from the current value. <p>Note that this value on this register is momentary. Before decreasing the guidepoint the bit needs to be cleared before setting it to one. Note that the guide point cannot at the extremes of the sensing window and will automatically truncated if the extreme limit is reached. The extreme limit depends on the sensor resolution and sensor width.</p>
11	0/1	Jog Right or increase guidepoint	<p>This bit performs two functions based on bit 9.</p> <p>If bit 9 is cleared:</p> <ul style="list-style-type: none"> 0: Stop Jog Right operation 1: Start Jog Right operation <p>Note that this register is a write only register and will not change state if the web guide reaches the extreme position.</p> <p>If bit 9 is set:</p> <ul style="list-style-type: none"> 0: will clear the register and has no effect 1: will increase the guide point by 0.254 mm or 1/100th of an inch from the current value. <p>Note that this value on this register is momentary. Before increasing the guidepoint the bit needs to be cleared before setting it to one. Note that the guide point cannot at the extremes of the sensing window and will automatically truncated if the extreme limit is reached. The extreme limit is set such that at least ± 3.175 mm is available on either side of the adjusted guide point.</p>
12	0/1	Servo Center operation or set guide point	<p>This bit performs two functions based on bit 9.</p> <p>If bit 9 is cleared:</p> <ul style="list-style-type: none"> 0: No effect 1: Start Servo Center operation

			<p>Note that this register is a write only register and will not change state if the web guide reaches the center position. Note that this value on this register is momentary. Before a servo center operation the bit needs to be cleared to zero before setting it to one.</p> <p>If bit 9 is set:</p> <ul style="list-style-type: none"> • 0: will clear the register and has no effect • 1: will set the guide point to be at 50% of the sensing window. <p>Note that this value on this register is momentary. Before decreasing the guidepoint the bit needs to be cleared before setting it to one. The extreme limit is set such that at least ±3.175 mm is available on either side of the adjusted guide point.</p>
13	0/1	Enable arbitrary gross guide point adjustment	<p>This bit allows arbitrary gross adjustment of the guide point offset through the industrial ethernet interface.</p> <p>0: if cleared to zero, gross guide point adjustment is disabled</p> <p>1: if set to one, the remote ethernet controller can make arbitrary gross adjustment to the guide point by writing a 16-bit signed integer to the guide point register.</p>
14-15	NA		Reserved for future

WARNING: All the remote control operations may cause the web guide to move without operator intervention. This process may cause process upsets. Caution must be exercised when performing these function and should be done by those who completely understand the consequence of this change.

WARNING: Web Guiding System enabled by SCU5 controller is an automatic control device that may stop and start at any time without notice, especially when controlled remotely. Hence standard safeguards must be in place to prevent any kind of injury.

WARNING: The remote control options provides significant access and control of the web guide and the sensor. A combination of the settings may create conditions that might not be ideal for web guiding. Hence only personnel familiar with the web guide operation should program the remote control interface. Contact Roll-2-Roll Technologies' technical support team for any question or assistance.

Guide point offset register

If the 13th bit of the web guide command register is set, then arbitrary guide point adjustment can be made by writing a 16-bit signed integer value to the guide point offset register. The offset value is the distance from the desired guide point location to the middle of the sensor window. A positive offset value will result in a guide point location towards the right half of the sensor window while a negative offset will result in a guide point location towards the left half of the sensor window. The guide point offset in mm = 0.0635*(the 16-bit guide point offset register).

Motor speed register

The positioning speed of the actuator can be changed by setting the 7th bit of the register to 1 and writing a value between 0 and 100 in the 7 least significant bits. If the 7th bit is low then the value written in the register is being ignored. Any value in the 15th to 8th bit within the register is also ignored.

Communication Module

Off-shelf industrial ethernet modules from [HMS industrial](#), are used in the SCU5 controller to provide ethernet connectivity. A 4-pin D-coded M12 socket connect is provided for ethernet connection. Standard network cables can be used to connect the SCU5 MC(x) to an ethernet network using RJ45 plug.

IP Address

The SCU5 MC(x) is configured to automatically acquire an IP address from a DHCP router or a server. As soon as the controller is connected to a network, an IP address is automatically assigned to the device. Before starting the configuration procedure find the IP address of the controller on the network.

Finding the IP Address

Once the controller is powered ON, the controller will automatically connect to the network. The controller is configured to get the IP address automatically from a DHCP server. Hence the controller should be connected to a network where dynamic IP addresses are issued by a network device such as a router.

A network port scan utility can be used to find the controller. Alternatively the [IPConfig](#) utility available in the software section of the [HMS Industrial website](#) can be used to scan for the device.

Once the utility is installed the program can be run to find the AnyBus IC module on the SCU5 MC(x). The following shows the opening screen of the IPconfig utility.

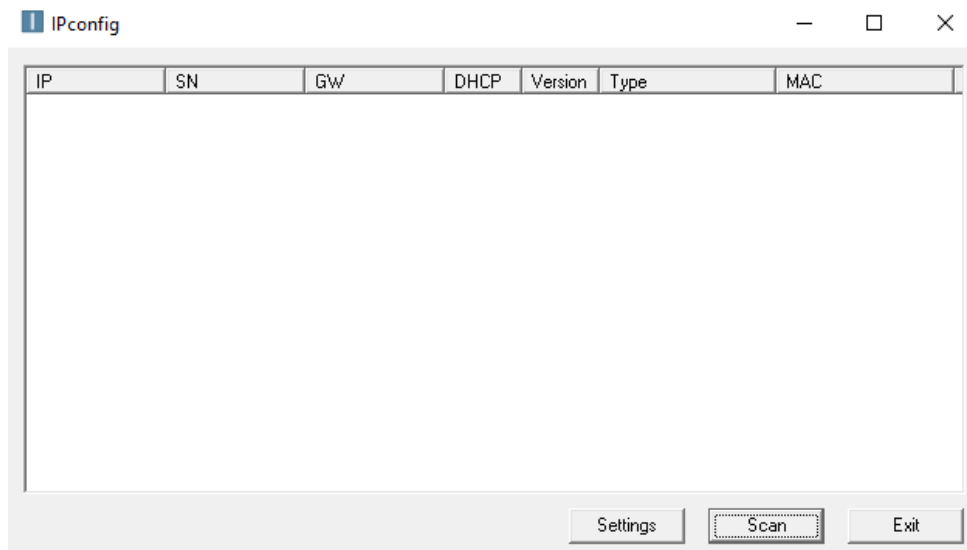

By pressing the scan button all the devices on the network from HMS Industrial network can be found. For example, the utility would find the device and list it as shown below.

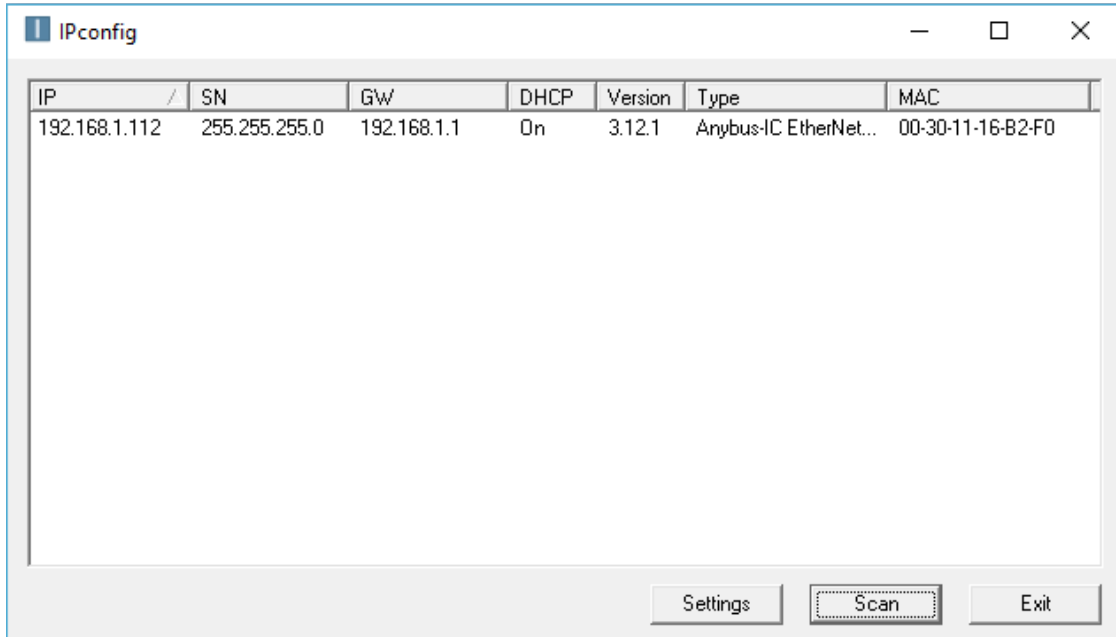

Information such as IP address, DHCP state, Type of module and the MAC address is displayed.

Setting a static IP address for the controller

Double clicking on the desired device listed in the IPConfig window would bring a screen to configure the Static/Dynamic IP address setting as shown below. By selecting the DHCP setting to be off, static IP address can be configured for the device.

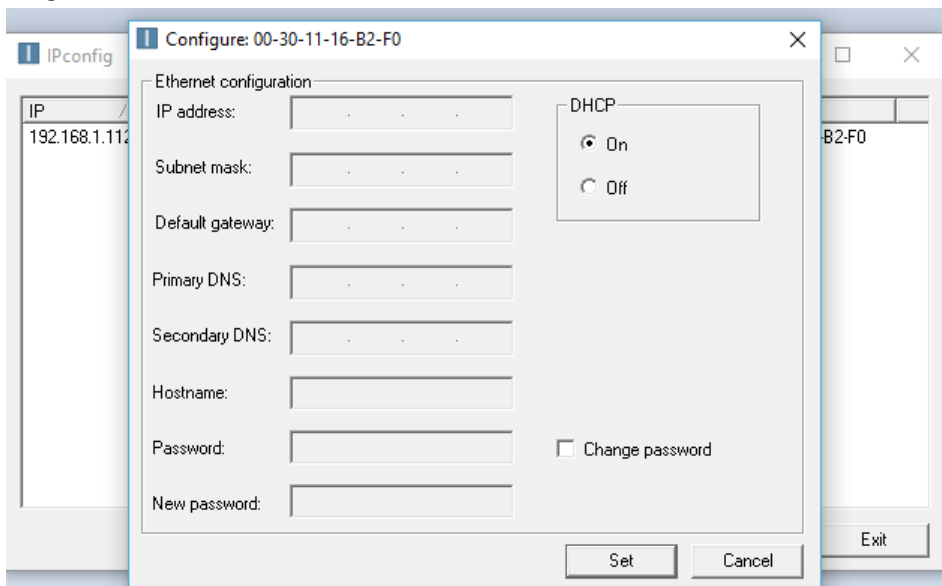

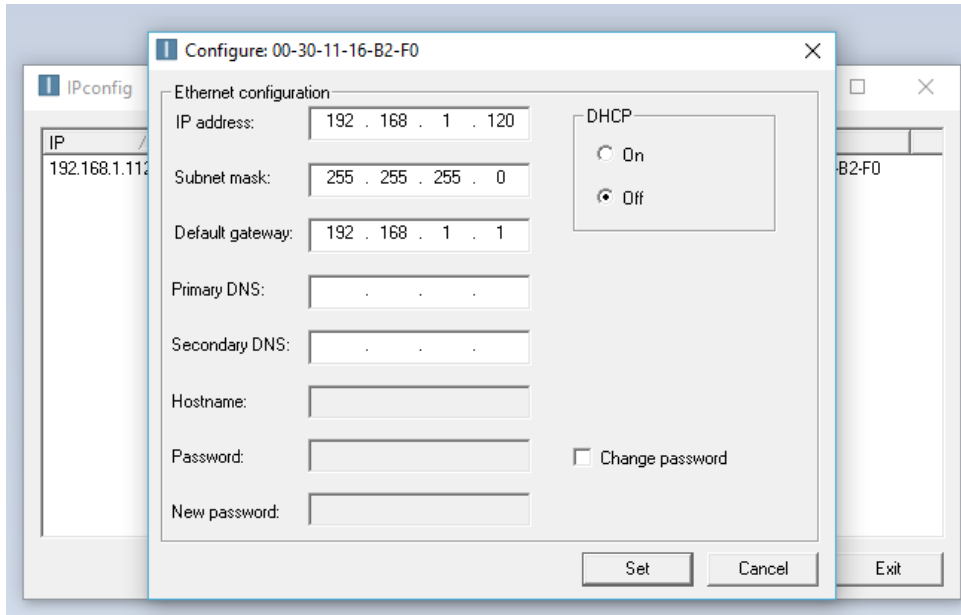

By clicking on the “Set” the static IP address can be set. Once the static IP address is set the IPconfig utility will refresh to show the new configuration. The DHCP setting will be set to “OFF” state and the new IP address will be assigned to the device as shown below.

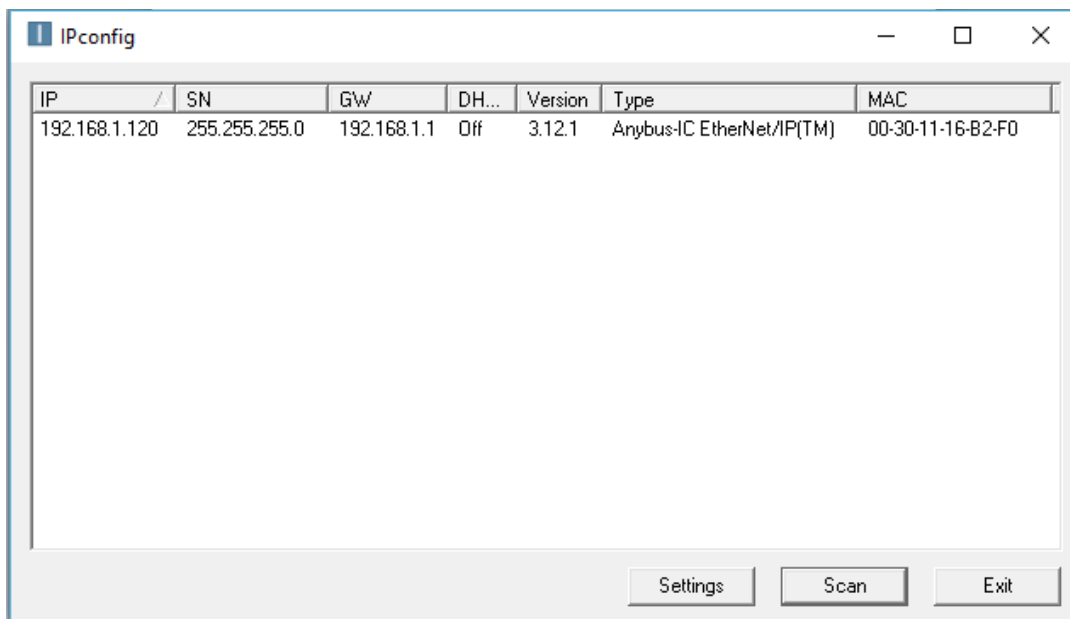

Adding an EtherNet/IP module in Rockwell/AB Ecosystem

Open Studio 5000 project for the PLC that needs to be connected to the SCU5 C(E) controller. Locate the Ethernet module in the I/O configuration of the controller organizer. Select the Ethernet module and right click to add a new module:

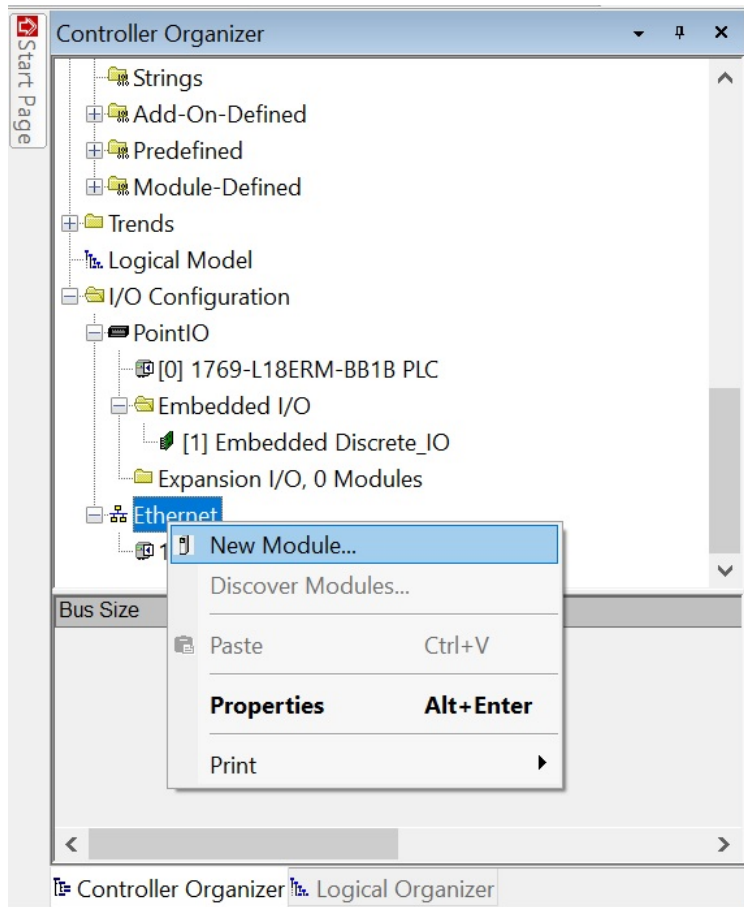

In the search box type “ethernet-module”, to add a generic ethernet module.

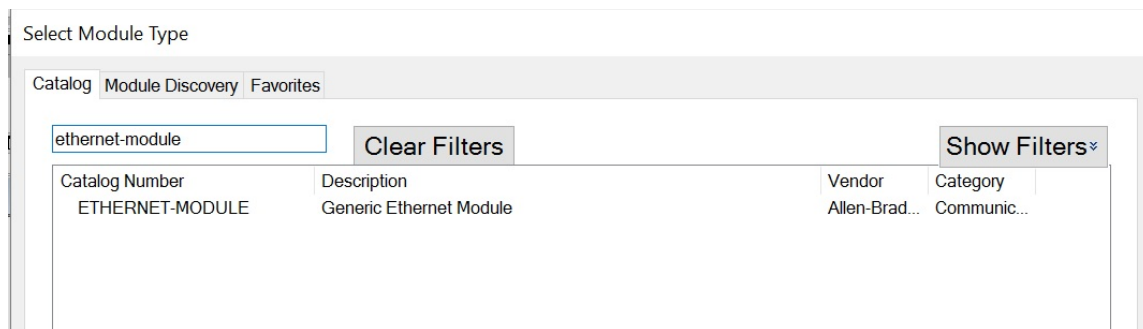

Configuring the module parameters

Once selected a property box will pop-up. In the property box, the name and description fields can be chosen arbitrarily. The communication data format **MUST** be changed to Data-INT in the drop down menu. The IP address **MUST** match the IP address of the sensor on the network. The connection parameters **MUST** match the one shown on the image below:

The screenshot shows the 'New Module' configuration dialog box. The 'Name' field is 'ArisWPS'. The 'Description' field is 'Ethernet module for the communication with ARIS web position sensor'. The 'Comm' dropdown is set to 'Data - INT'. The 'Address / Host Name' section has the 'IP Address' radio button selected, with the address '192 . 168 . 0 . 102'. The 'Connection Parameters' section has three rows: 'Input' with 'Assembly Instance' 100 and 'Size' 8 (16-bit); 'Output' with 'Assembly Instance' 150 and 'Size' 8 (16-bit); and 'Configuration' with 'Assembly Instance' 1 and 'Size' 0 (8-bit). There are also 'Status Input' and 'Status Output' fields. At the bottom, there is a checkbox for 'Open Module Properties' which is checked, and three buttons: 'OK', 'Cancel', and 'Help'.

In the connection parameters choose the input assembly instance to start at 100 with a size of 8 (16-bit), output to start at 150 with a size of 8 (16-bit) and the configuration to 1 with a size of 0. Check "Open Module Properties" and press OK.

Configuring communication options

The next step involves the communication option configuration. The RPI sets the frequency at which the data is exchanged, lower RPI would imply a higher network load and vice versa. The sensor update the data every 20ms, therefore any RPI lower than that would not result in any extra meaningful data. Set the RPI to be 20 ms.

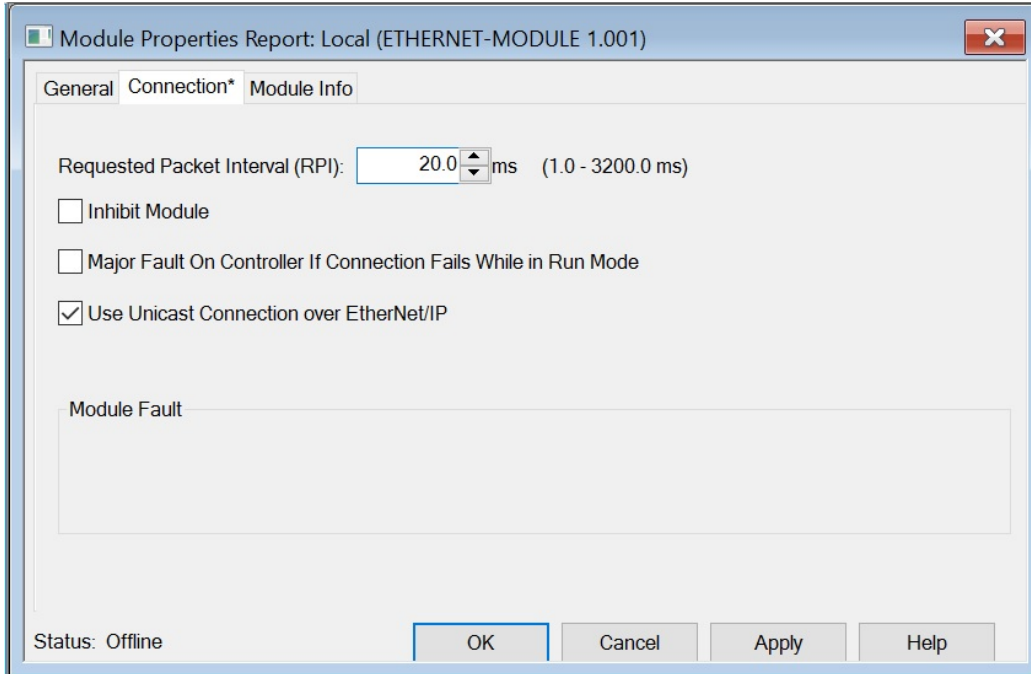

Click "Apply" to add the module.

Importing Add-On-Instruction

Roll-2-Roll Technologies provides an Add-On-Instruction (AOI) to easily interface the sensor as well as the web guide. To import the AOI: select the Add-On Instruction in the controller organizer, right click and select import Add-On Instruction:

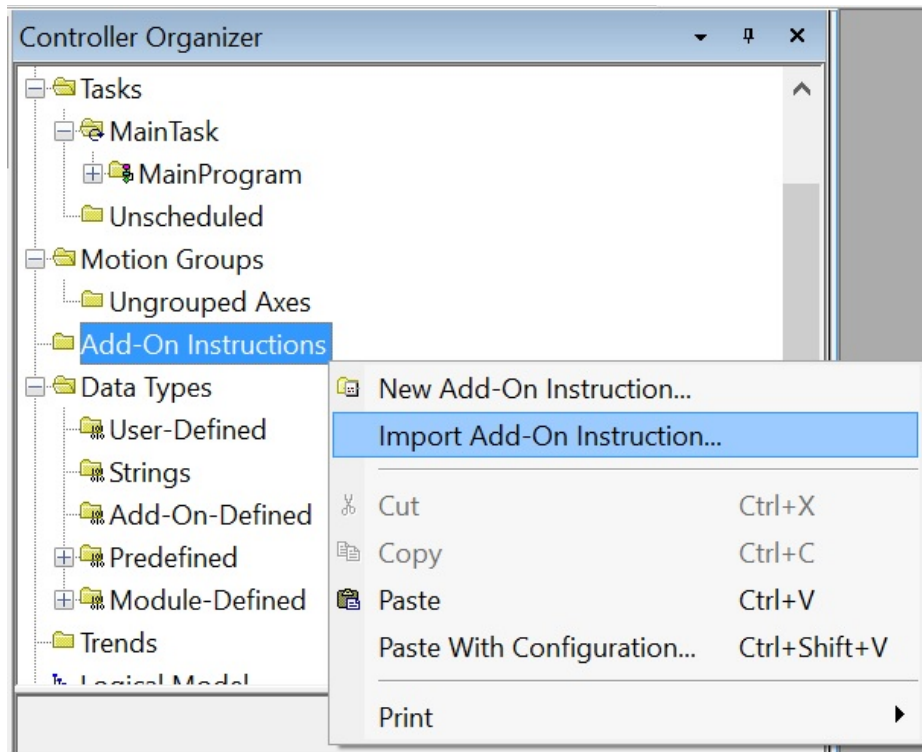

For example, importing the AOI for sensor is shown in the following.

Select the ARIS_SensorInterface.L5X file provided by Roll-2-Roll Technologies.

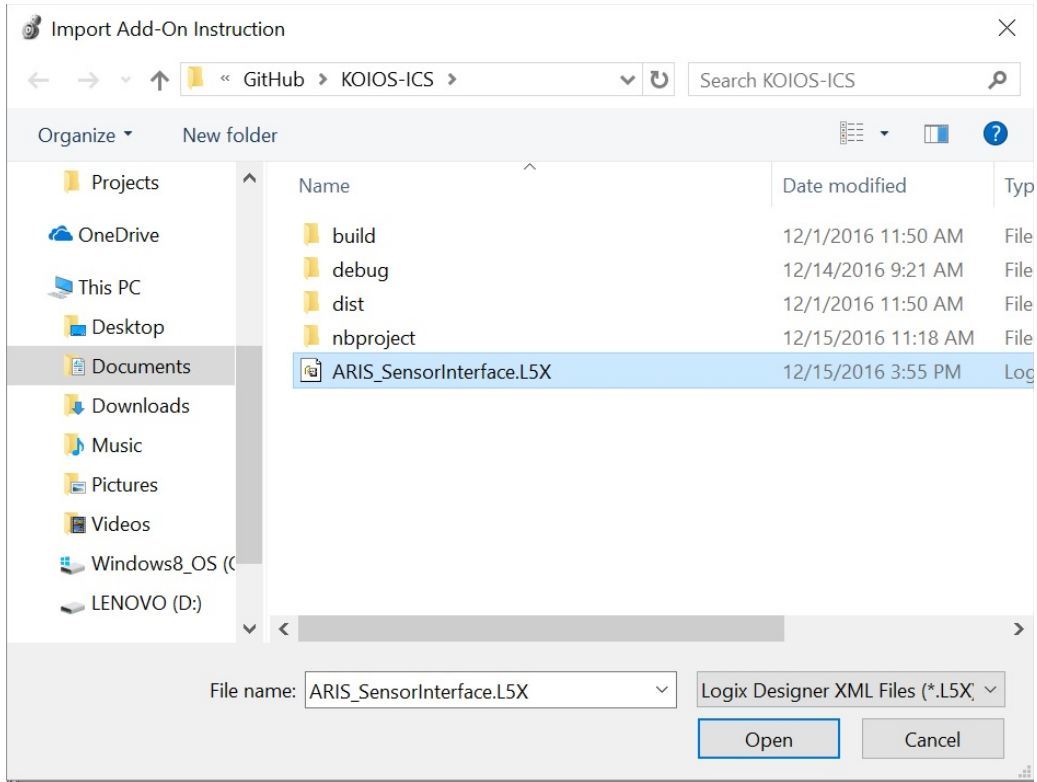

Once imported the AOI logic and user defined variables will appear in the controller organizer:

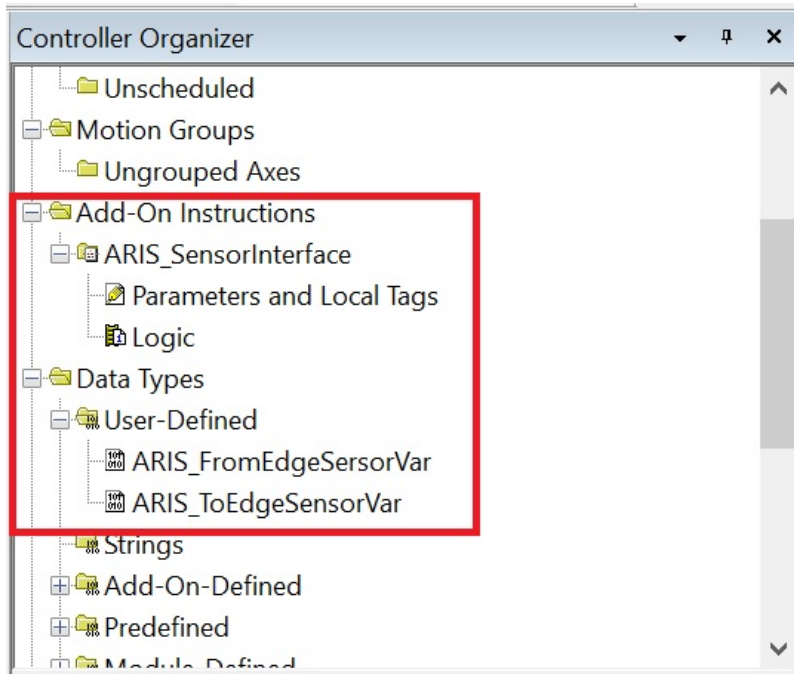

Using SCU5 C(E) Add-On Instruction

Once imported, ARIS AOI will appear in the Add-on tab from which it can be added to the project.

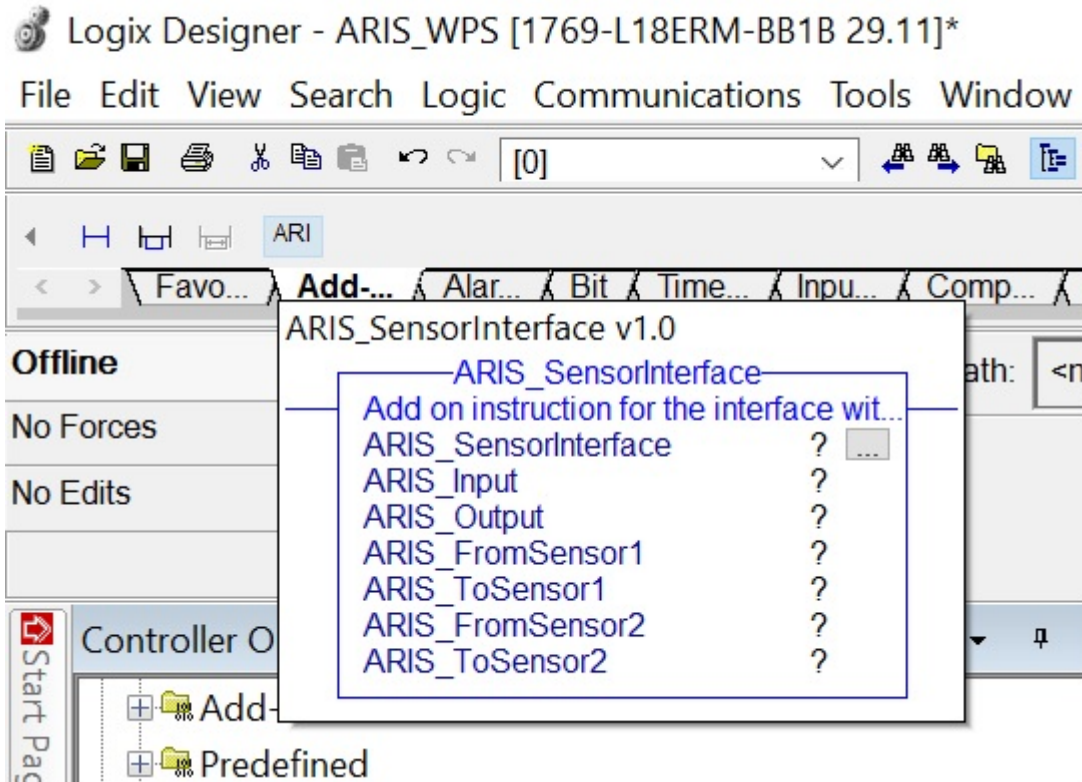

Once dropped in a rung simply fill the variables in the AOI.

Note: the *ARIS_Input* and *ARIS_Output* variable **MUST** match the variable of the ARIS Ethernet module.

All other variable can be named arbitrarily. In this example the *ARIS_Input* is mapped to *ARIS_WPS:I.Data* and *ARIS_Output* is mapped to *ARIS_WPS:O.Data*.

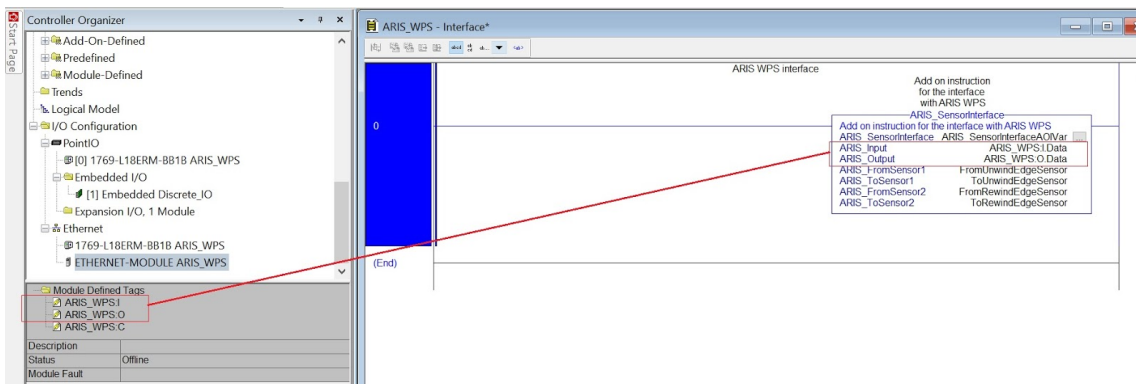

Sensor variables

SCU5 C(E) sensor variables are defined to make the integration of the sensor easy for the user without having to worry about the mapping and decoding the input and output registers. There are two types of variables: ARIS_FromWebEdgeSensorVar and ARIS_ToWebEdgeSensorVar. The first one contains all the data coming from the sensor, the second all the data that can be sent to the SCU5 C(E) to control the sensor. The sensor related data coming from the controller is read from the sensor output registers. The image below shows an instance of the ARIS_FromWebEdgeSensorVar variable with all the available fields. In this instance FromRewindEdgeSensor is the name of the variable of type ARIS_FromWebEdgeSensorVar. The PLC program can use these variables to monitor the status/fault as well as obtain the measurement information from the sensor.

[- FromRewindEdgeSensor		{ . . . }	{ . . }		ARIS_Fro...
	FromRewindEdgeSensor.NoSensor	0	Decimal		BOOL
	FromRewindEdgeSensor.LowContrast	0	Decimal		BOOL
	FromRewindEdgeSensor.NoWeb	0	Decimal		BOOL
	FromRewindEdgeSensor.WorngOri...	0	Decimal		BOOL
	FromRewindEdgeSensor.Flutter	0	Decimal		BOOL
	FromRewindEdgeSensor.LeftSensor	0	Decimal		BOOL
	FromRewindEdgeSensor.RightSensor	0	Decimal		BOOL
	+ FromRewindEdgeSensor.NumberOfP...	0	Decimal		INT
	+ FromRewindEdgeSensor.SensorMode	0	Decimal		INT
	+ FromRewindEdgeSensor.EdgePixel	0	Decimal		DINT
	FromRewindEdgeSensor.Edge_mm	0.0	Float		REAL
	+ FromRewindEdgeSensor.QualityFactor	0	Decimal		INT

The image below shows an instance of the ARIS_ToWebEdgeSensorVar which can be used in the PLC program to control/command the sensor through the SCU5 C(E).

[- ToRewindEdgeSensor		{ . . . }	{ . . }		ARIS_ToE...
	ToRewindEdgeSensor.ForceRightSe...	0	Decimal		BOOL
	ToRewindEdgeSensor.ForceLeftSen...	0	Decimal		BOOL
	ToRewindEdgeSensor.FindSensor	0	Decimal		BOOL
	ToRewindEdgeSensor.AutoSwitchOff	0	Decimal		BOOL
	+ ToRewindEdgeSensor.SensorMode	0	Decimal		INT
	ToRewindEdgeSensor.OutputDis	0	Decimal		BOOL



COMMISSIONING

Sensing and Measurement Application

Depending on the application one or two sensors may need to be connected to the controller. Using the functionality described in the previous section, the output of the controller should be configured appropriately. Once the settings are configured, the user need not interact with the controller at all. The only interaction required will be for contrast setup functionality. The screen can be used for monitoring purposes.

Web Guiding Application

A properly installed web guide requires correct threading of the web over the guide rollers and initial positioning of the sensor based on the desired position of the web to provide optimum performance. Once the material is threaded over the guide rollers and the sensor has been properly positioned, all the operator has to do is to press the automatic operation icon on the operator interface. Please refer to the respective sensor and web guide manual for proper installation of the web guiding system.

The following section describes the steps and conditions required for automatic operation with a SCU5 M web guide controller.

Edge Guiding

1. Power ON the system
2. Automatic/Manual operation set to "Manual" (Automatic/Manual icon pressed to red)
3. Jog the guide to left extreme and then to right extreme to correct for any transportation related guide roller assembly movements.
4. Press the Servo-Center button to center the guide rollers.
5. Thread the material over the rollers. The material wrapped over the rollers must be at a 90 degree angle both at the entry and exit of the guide rollers.
6. Verify that the material is aligned in the desired position with respect to the upstream and downstream position of the web. Place web under normal operation tension.
7. Adjust sensor position on the desired edge of the web. Then manually position the sensor so that the edge of the web is at the middle of the sensing window. This can be done by observing the web edge position indicator on the display. When the bar is in the middle position then the web edge is in the middle of the sensing window.
8. If the sensor position indicator and the actual position of the sensor are different then press the "Find Sensor" button on the operator interface so that the controller automatically find the correct orientation of the edge sensor. In order for this function to work the web edge needs to be in the middle of the sensing window.
9. Tighten the sensor thumbscrews or the brake on the sensor to secure the sensor position on the sensor rail.
10. Press the Automatic/Manual operation icon to "Automatic" (Automatic/Manual icon pressed to green).

11. The guide will automatically adjust the position of the web material to guide it to the correct position.

Center Guiding Application

For center guiding application follow the same steps for each sensor before enabling the automatic guiding mode.

Standard Operating Procedure

The standard operating procedure for the web guide controller involves the following steps.

1. During startup or change over, servo center the web guide to its home/middle position.
2. Thread the web at the desired location on the web guide rollers.
3. If the guide point is offset is not needed then reset the guide point offset to zero.
4. For edge guiding applications, position the sensor such that the web aligns with the guide point location on the screen.
5. If manual positioning of the sensor is not desired, use the reset guide point operation to digitally move the guide point to the current web position. This is mostly applicable with wide sensors when the new location of the web is still within the sensing window of the sensor.
6. If web is guided to the center line position, reset the guide point to the current location of the web while ensuring that both edges are seen by the sensors.
7. Set the web guide in automatic mode.
8. If during operation fine adjustments to the guide point are needed, then use the fine guide point adjustment procedure to make the necessary changes while the web guide is in automatic mode. The effect of the guide point adjustment will be seen only when the web is moving.
9. Once the line is stopped for changeover or production stoppage, set the web guide to manual mode and if needed servo center the web guide to its home/middle position.

General Maintenance

There is no general maintenance required for the web guide controller. Please refer to the respective sensor and web guide manual for maintenance information.

TROUBLESHOOTING

Problem	Probable Cause	Action
Sensor indicator does not light up and the sensor does not find the web.	Background or faulty sensor cable or connection.	<ul style="list-style-type: none"> * Ensure that the background in the field of view of the sensor is dark. Any bright surfaces may reduce the contrast levels and can prevent automatic find sensor operations. * Ensure that the sensor cable is properly connected. Disconnect the cable and reconnect it and use the find sensor button procedure. * If that does not fix the problem try a different sensor head. * If that does not fix the problem please call support.
The touch screen does not work and the communication indicator is not blinking.	Communication between the electronic hardware and the operator interface is lost.	<ul style="list-style-type: none"> * Power cycle the controller to see if the communication is reestablished. * If that does not fix the problem, please call support.
The web guide is not moving in automatic mode.	Faulty cable or connection. or Software soft stop reached.	<ul style="list-style-type: none"> * Check the sensor cables and connection to ensure that the sensor sees the web. * If the sensor works properly, then try to manually jog the web guide away from the center position. The web guide will stop jogging when the software soft stop is reached. While jogging, the actuator may produce a noise because of the hard stop. It is normal. Once the software stops jogging, push the automatic button again. * If that does not fix the problem, please call support.

TECHNICAL SUPPORT AND SERVICE

Contact information

Roll-2-Roll Technologies LLC is dedicated to providing exceptional service and support to its customers. Please feel free to contact us for any technical support, installation support and service requirements.

Roll-2-Roll Technologies LLC
1110 S Innovation Way Dr
Stillwater, OK 74074
Website: <https://www.r2r-tech.com>

Technical Support Phone: +1 (888) 290-3215 - ext 3
General Support Phone: +1 (888) 290-3125 - ext 1

Technical Support Email: engineering@r2r-tech.com
General Support Email: support@r2r-tech.com

Return shipping instructions

Please contact us to obtain a return merchandise authorization (RMA) number before returning the product to us. If returning the product, please follow the instructions on the RMA form for quick and efficient service.

REVISION HISTORY

Document Revision

Version	Date	Changes
1.0	Sep 2015	Initial Release Version
1.1	Feb 2016	Comprehensive revision and new sections added: safety instructions, mounting dimensions, troubleshooting, specifications.
2.0	Jun 2016	Updated documentation for SCU V4 Rev D hardware, firmware and OI.
2.2	Dec 2016	Updated documentation for firmware updates and usability changes
2.4	Jun 2017	Updated documentation for firmware updates and operator interface changes
2.6	Nov 2018	Updated documentation for firmware updates and operator interface changes
3.3	Dec 2018	Updated documentation for contrast sensor capabilities

Hardware Revision

Version	Date	Description
SCU V2	Dec 2014	Initial version with 12 VDC input
SCU V3	Jun 2015	Expanded version with 24 VDC input
SCU V4 Rev B	Oct 2015	Two sensor option, WDT, RTCC
SCU V4 Rev C	Mar 2016	Analog Output
SCU V4 Rev D	July 2016	Industrial ethernet option
SCU5 Rev B	May 2017	Smaller form factor board
SCU5 Rev C	Nov 2017	Robustness improvements

Firmware Revision

Version	Date	Description
1.0	Jan 2015	Initial version, single sensor
1.1	Aug 2015	Firmware update for SCU V3, automatic sensor state detection
1.2	Nov 2015	Firmware update for SCU V4 Rev B. Modified sensor algorithm to increase precision and accuracy.

1.3	Dec 2015	Two sensor option with automatic pixel detection
1.4	Mar 2016	Background suppression algorithm
1.5	Apr 2016	Analog output
2.1a	Aug 2016	Firmware update for SUC V4 Rev D
2.2b	Dec 2016	Ethernet/IP implicit messaging, edge detection algorithm updates
2.4a	Jun 2017	Changes to guide point adjustment and Ethernet/IP registers
2.5	Apr 2018	Minor bug fixes, enabled password protected screen
2.6	Nov 2018	Provided more access to internal settings of the controller for power users.
3.3	Dec 2018	Updated functionality to version 3 algorithm.



Roll-2-Roll Technologies LLC
 1110 S Innovation Way Dr
 Stillwater, OK 74074
www.r2r-tech.com
info@r2r-tech.com
 +1-(888)-290-3215